

# My Pattern, My Life!

As usual, we keep on developing new products and provide the best quality and service to the worldwide customers.

In the year of 2012, we raise the level of our products even better than before. After repeatedly testing and improving, we successfully applied the water transfer printing technique to our products.

There are four different ways:

1<sup>st</sup> Water transfer technique

2<sup>nd</sup> Non-film transfer technique

3<sup>rd</sup> 3D transfer technique

4<sup>th</sup> Mirror silver transfer technique

Compared to a regular printing, the new techniques produces brighter and more vivid colors with six to eight times of the thickness, and it's also UV-resistant, anti-wear out and waterproof.

And this printing technique not only meets the standards such as EN71-3, ASTM, CNS, ROHS and REACH, but also passes the Cross hatches test, Hardness test, Bend test and the Impact test which is not a regular printing technique can achieve.

We keep improving and innovating our products to let our customers to have more choices. By customizing productions, we will make our company more valuable, just like our main idea: My Pattern, My life! Quality Never Compromise!





**W53-10PX**



**W42-S7X**



**W53-11X**



**W42-10PX**



**W53-13X**



**W42-11X**



**W53-9XS**



**W42-13X**



**W53LS-7X**



**W42LS-7X**



**W53D-14X**



**W42D-16X**



**W53LS-6XS**



**W42LS-5XS**



**EP666D-8BX**



**EP555D-8BX**





**W26-3KXL**



**W26-3PX**



**W26-5PX**



**W26-5X**



**W26-6X**



**W26-6XL**



**W26-7X**



**W26-8X**



**W26-10X**



**W15-S3X**



**W15-S4X**



**W15-5X**



**W15-7X**



**W15-S7**



**W15-H7**



**W26-B4X**



**W26-B4X-W**



**W26-B4X+W26-B4X-W**



**EP222-4AX**



**EP222-5AX**



**EP222-6AX**



**EP222-7AX**



**EP222-9AX**



**EP222-4BX**



**EP222-5BX**



**EP222-6BX**



**EP222-7BX**



**EP222-8BX**





**EP222-9BX**



**EP222-11BX**



**EP333-5AX**



**EP333-6AX**



**EP333-10AX**



**EP333-12AX**



**EP333-I-3X**



**I-3X**



**EP333-5BX**



**EP333-6BX**



**EP333-10BX**



**EP333-12BX**



ET302



ET303



ET303L



ET304



ET303TL1



T28



T28-1X



T28-3X



**WB59-A**



**WB59-B**



**WB59-C**



**WB59-D**



**WB59-E**



**WB59-F**



**WB50E-A**



**WB50E-B**



**WB50E-C**



**WB50E-D**





**EP212LX**



**EP213X**



**EP223X**



**EP214X**



**EM0005**



**EM0005X**



**S23B(S)**



**S23B(L)**



**ES-2**



**ES-4**



**WB26**



**WB32**

1. Fully shelf-closing ball bearing slide.
2. Large diameter surface covered handle, excellent sensible touching.
3. 6"x2" heavy duty roller column caster. (2 swivel + 2 swivel with brake)
4. Protecting top of surface with 15mm thick particle board on top of roll-wagon.
5. One piece steel of cabinet body provide more strength to whole one unit body structure.
6. Multiple numbers internal locking system for extra security.
7. Quick release design on ball bearing slide can be easily removed for replacement.
8. 100% open ball bearing slide.
9. Strengthen lower part under large drawer, can be loaded with extra large size tools capacity.
10. Patented locking system, pushing unlocked drawer to be locked while all others are locked.
11. Drawers are interchangeable.
12. Four fixture on two sides, can be attached and hanged other equipment.
13. Powder coating finishing.
14. Hemmed edge for all drawers and body to add strength and safety.
15. 2mm protective drawer liners.

**Steel thickness:**

Top and bottom cover: 1.5mm

Body: 1.2mm

Drawer: 1.0mm

## W53-13X

### 53" 13-Drawer Roll-Wagon

#### Fully Shelf-Closing Ball Bearing Slides

	W	D	H	
<b>Overall</b>	53	18	38 5/8	in.
	1358	460	980	mm
<b>Overall</b>	53	18	45 1/4	in.
<b>With 6" Casters</b>	1358	460	1150	mm
<b>10 Drawers</b>	22 5/8	15	2 15/16	in.
	576	380	75	mm
<b>2 Drawers</b>	22 5/8	15	6	in.
	576	380	154	mm
<b>1 Drawers</b>	47 13/16	15	6 13/16	in.
	1215	380	173	mm
	<b>N.W.</b>	<b>G.W.</b>	<b>CUFT</b>	
	166 KGS	177 KGS	31.54'	

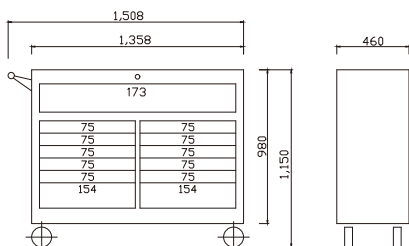

**PAT. NO.**

M267303(TW)

M282635(TW)

766086(CN)

Nr.202005000374.3



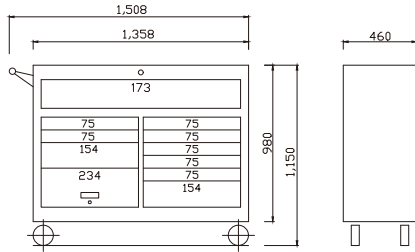

## W53-10PX

53" 10-Drawer Roll-Wagon  
With Bulk Storage Compartment  
Fully Shelf-Closing  
Ball Bearing Slides

	W	D	H	
Overall	53	18	38 5/8	in.
	1358	460	980	mm
Overall	53	18	45 1/4	in.
With 6" Casters	1358	460	1150	mm
7 Drawers	22 5/8	15	2 15/16	in.
	576	380	75	mm
2 Drawers	22 5/8	15	6	in.
	576	380	154	mm
1 Drawers	47 13/16	15	6 13/16	in.
	1215	380	173	mm
Panel Are	23 11/16	15 7/8	9 1/4	in.
	603	404	234	mm
	<b>N.W.</b>	<b>G.W.</b>	<b>CUFT</b>	
	151 KGS	162 KGS	31.54'	

## W53-11X

53" 11-Drawer Roll-Wagon  
Fully Shelf-Closing  
Ball Bearing Slides

	W	D	H	
Overall	53	18	38 5/8	in.
	1358	460	980	mm
Overall	53	18	45 1/4	in.
With 6" Casters	1358	460	1150	mm
8 Drawers	22 5/8	15	2 15/16	in.
	576	380	75	mm
2 Drawers	22 5/8	15	6	in.
	576	380	233	mm
1 Drawers	47 13/16	15	6 13/16	in.
	1215	380	173	mm
	<b>N.W.</b>	<b>G.W.</b>	<b>CUFT</b>	
	158 KGS	169 KGS	31.54'	

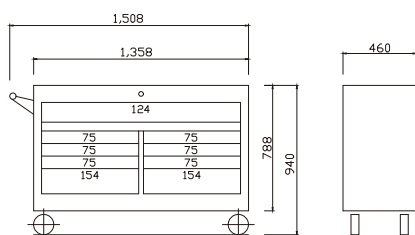
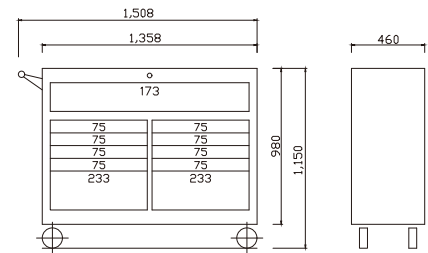

## W53-9XS

53" 9-Drawer Roll-Wagon  
Fully Shelf-Closing  
Ball Bearing Slides

	W	D	H	
Overall	53	18	30 3/8	in.
	1358	460	770	mm
Overall	53	18	37	in.
With 6" Casters	1358	460	940	mm
6 Drawers	22 5/8	15	2 15/16	in.
	576	380	75	mm
2 Drawers	22 5/8	15	6	in.
	576	380	154	mm
1 Drawers	47 13/16	15	4 7/8	in.
	1215	380	124	mm
	<b>N.W.</b>	<b>G.W.</b>	<b>CUFT</b>	
	136 KGS	146 KGS	23.9'	



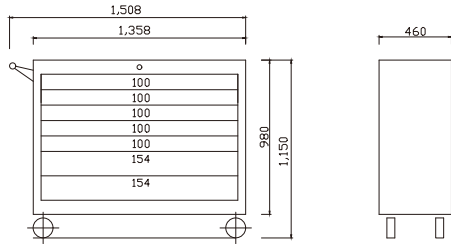

## W53LS-7X

53" 7-Drawer Roll-Wagon  
Fully Shelf-Closing, Ball Bearing Slides  
One Drawer Open at a Time Locking System

	W	D	H	
Overall	53	18	38 5/8	in.
	1358	460	980	mm
Overall	53	18	45 1/2	in.
With 6" Casters	1358	460	1150	mm
5 Drawers	47 7/8	15	3 15/16	in.
	1215	380	100	mm
2 Drawers	47 7/8	15	6	in.
	1215	380	154	mm
<b>N.W.</b>	<b>140 KGS</b>	<b>G.W.</b>	<b>150 KGS</b>	<b>CUFT</b>
			31.54'	

## W53D-14X

53" 14-Drawer Roll-Wagon  
Fully Shelf-Closing  
Ball Bearing Slides

	W	D	H	
Overall	53	18	38 5/8	in.
	1358	460	980	mm
Overall	53	18	45 1/4	in.
With 6" Casters	1358	460	1150	mm
10 Drawers	22 5/8	15	2 15/16	in.
	576	380	75	mm
3 Drawers	22 5/8	15	6	in.
	576	380	154	mm
1 Drawers	22 5/8	15	12 1/4	in.
	576	380	312	mm
<b>N.W.</b>	<b>155 KGS</b>	<b>G.W.</b>	<b>166 KGS</b>	<b>CUFT</b>
			31.54'	

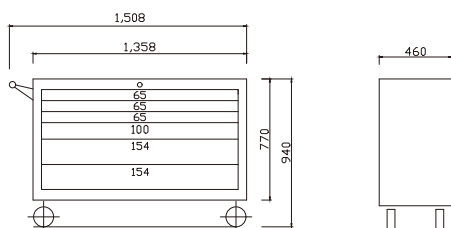
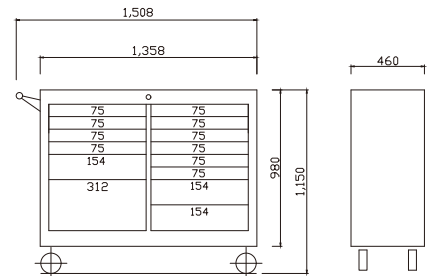

## W53LS-6XS

53" 6-Drawer Roll-Wagon  
Fully Shelf-Closing, Ball Bearing Slides  
One Drawer Open at a Time Locking System

	W	D	H	
Overall	53	18	30 3/8	in.
	1358	460	770	mm
Overall	53	18	37	in.
With 6" Casters	1358	460	940	mm
3 Drawers	47 7/8	15	2 1/2	in.
	1215	380	65	mm
1 Drawers	47 7/8	15	3 15/16	in.
	1215	380	100	mm
2 Drawers	47 7/8	15	6	in.
	1215	380	154	mm
<b>N.W.</b>	<b>128 KGS</b>	<b>G.W.</b>	<b>138 KGS</b>	<b>CUFT</b>
			23.9'	

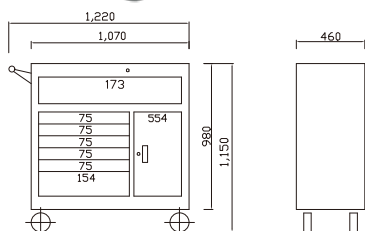

## W42-S7X

42" 7-Drawer Roll-Wagon  
With Bulk Storage Compartment  
Fully Shelf-Closing  
Ball Bearing Slides

	W	D	H	
Overall	42	18	38 5/8	in.
	1070	460	980	mm
Overall	42	18	45 1/4	in.
With 6" Casters	1070	460	1150	mm
5 Drawers	22 5/8	15	2 15/16	in.
	576	380	75	mm
1 Drawers	22 5/8	15	6	in.
	576	380	154	mm
1 Drawers	36 1/2	15	6 13/16	in.
	927	380	173	mm
Panel Are	12 1/2	15 7/8	21 13/16	in.
	317.5	404	554	mm
	<b>N.W.</b>	<b>G.W.</b>	<b>CUFT</b>	
	129 KGS	139 KGS	25'	

## W42-10PX

42" 10-Drawer Roll-Wagon  
With Bulk Storage Compartment  
Fully Shelf-Closing  
Ball Bearing Slides

	W	D	H	
Overall	42	18	38 5/8	in.
	1070	460	980	mm
Overall	42	18	45 1/4	in.
With 6" Casters	1070	460	1150	mm
5 Drawers	11 5/16	15	2 15/16	in.
	288	380	75	mm
2 Drawers	22 5/8	15	2 15/16	in.
	576	380	75	mm
1 Drawers	11 5/16	15	6	in.
	288	380	154	mm
1 Drawers	22 5/8	15	6	in.
	576	380	154	mm
1 Drawers	36 1/2	15	6 13/16	in.
	927	380	173	mm
Panel Are	23 11/16	15 7/8	9 1/4	in.
	603	404	234	mm
	<b>N.W.</b>	<b>G.W.</b>	<b>CUFT</b>	
	137 KGS	147 KGS	25'	

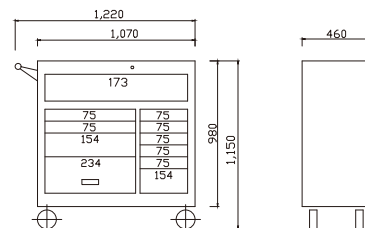

## W42-11X

42" 11-Drawer Roll-Wagon  
Fully Shelf-Closing  
Ball Bearing Slides

	W	D	H	
Overall	42	18	38 5/8	in.
	1070	460	980	mm
Overall	42	18	45 1/4	in.
With 6" Casters	1070	460	1150	mm
4 Drawers	11 5/16	15	2 15/16	in.
	288	380	75	mm
4 Drawers	22 5/8	15	2 15/16	in.
	576	380	75	mm
1 Drawers	11 5/16	15	9 3/16	in.
	288	380	233	mm
1 Drawers	22 5/8	15	9 3/16	in.
	576	380	233	mm
1 Drawers	36 1/2	15	6 13/16	in.
	927	380	173	mm
	<b>N.W.</b>	<b>G.W.</b>	<b>CUFT</b>	
	149 KGS	159 KGS	25'	

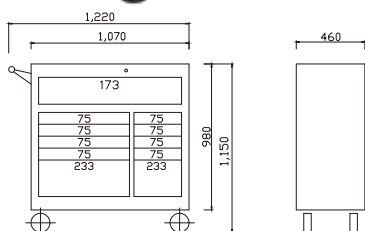

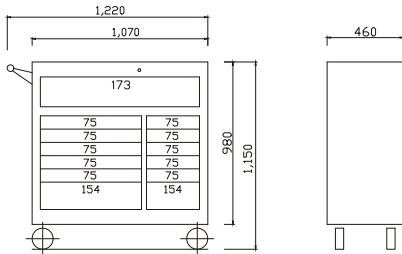

## W42-13X

42" 13-Drawer Roll-Wagon  
Fully Shelf-Closing  
Ball Bearing Slides

	W	D	H	
Overall	42	18	38 5/8	in.
	1070	460	980	mm
Overall	42	18	45 1/4	in.
With 6" Casters	1070	460	1150	mm
5 Drawers	11 5/16	15	2 15/16	in.
	288	380	75	mm
5 Drawers	22 5/8	15	2 15/16	in.
	576	380	75	mm
1 Drawers	11 5/16	15	6	in.
	288	380	154	mm
1 Drawers	22 5/8	15	6	in.
	576	380	154	mm
1 Drawers	36 1/2	15	6 13/16	in.
	927	380	173	mm
	<b>N.W.</b>	<b>G.W.</b>	<b>CUFT</b>	
	152 KGS	162 KGS	25'	

## W42LS-7X

42" 7-Drawer Roll-Wagon  
Fully Shelf-Closing, Ball Bearing Slides  
One Drawer Open at a Time Locking System

	W	D	H	
Overall	42	18	38 5/8	in.
	1070	460	980	mm
Overall	42	18	45 1/4	in.
With 6" Casters	1070	460	1150	mm
5 Drawers	36 1/2	15	3 15/16	in.
	927	380	100	mm
2 Drawers	36 1/2	15	6	in.
	927	380	154	mm
	<b>N.W.</b>	<b>G.W.</b>	<b>CUFT</b>	
	130 KGS	140 KGS	25'	

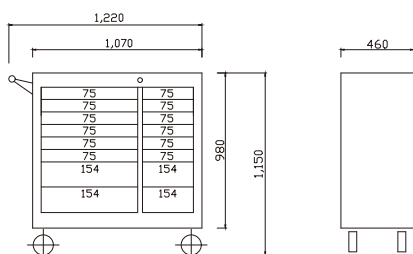
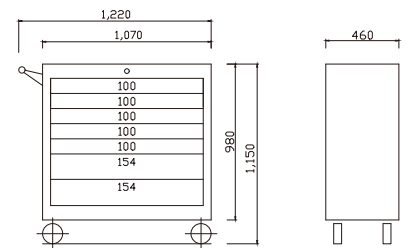

## W42D-16X

42" 16-Drawer Roll-Wagon  
Fully Shelf-Closing  
Ball Bearing Slides

	W	D	H	
Overall	42	18	38 5/8	in.
	1070	460	980	mm
Overall	42	18	45 1/4	in.
With 6" Casters	1070	460	1150	mm
6 Drawers	11 5/16	15	2 15/16	in.
	288	380	75	mm
6 Drawers	22 5/8	15	2 15/16	in.
	576	380	75	mm
2 Drawers	11 5/16	15	6	in.
	288	380	154	mm
2 Drawers	22 5/8	15	6	in.
	576	380	154	mm
	<b>N.W.</b>	<b>G.W.</b>	<b>CUFT</b>	
	142 KGS	152 KGS	25'	



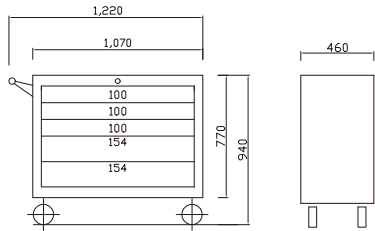

**W42LS-5XS**

42" 5-Drawer Roll-Wagon  
Fully Shelf-Closing, Ball Bearing Slides  
One Drawer Open at a Time Locking System

	W	D	H	
Overall	42	18	38 5/8	in.
	1070	460	770	mm
Overall	42	18	37	in.
With 6" Casters	1070	460	940	mm
3 Drawers	36 1/2	15	3 15/16	in.
	927	380	100	mm
2 Drawers	36 1/2	15	6	in.
	927	380	154	mm
<b>N.W.</b>	<b>106 KGS</b>	<b>G.W.</b>	<b>115 KGS</b>	<b>CUFT</b>
			18.3'	

**EP555D-8BX**

42" 8-Drawer Full Size Top Chest  
Ball Bearing Slides  
The Cover With Gas Spring

	W	D	H	
Overall	41 3/8	17 15/16	22 1/4	in.
	1050	455	566	mm
3 Drawers	11 5/16	15	2 15/16	in.
	288	380	75	mm
3 Drawers	22 5/8	15	2 15/16	in.
	576	380	75	mm
1 Drawers	11 5/16	15	6	in.
	288	380	154	mm
1 Drawers	22 5/8	15	6	in.
	576	380	154	mm
<b>N.W.</b>	<b>71.7 KGS</b>	<b>G.W.</b>	<b>77 KGS</b>	<b>CUFT</b>
			15.2'	

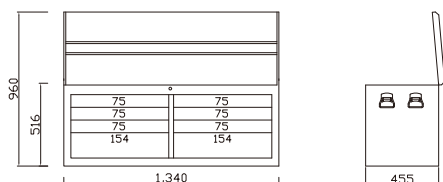
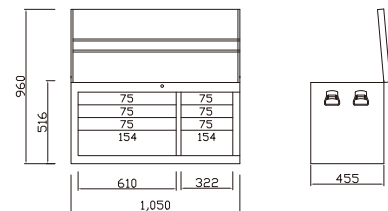

**EP666D-8BX**

53" 8-Drawer Full Size Top Chest  
Ball Bearing Slides  
The Cover With Gas Spring

	W	D	H	
Overall	52 3/4	17 15/16	22 1/4	in.
	1340	455	566	mm
6 Drawers	22 5/8	15	2 15/16	in.
	576	380	75	mm
2 Drawers	22 5/8	15	6	in.
	576	380	154	mm
<b>N.W.</b>	<b>84 KGS</b>	<b>G.W.</b>	<b>89.3 KGS</b>	<b>CUFT</b>
			18.8'	

1. One piece steel of cabinet body provide more strength to whole one unit body structure.
2. Hemmed edge for all drawers and body to add strength and safety.
3. Multiple numbers internal locking system for extra security.
4. Quick release design on ball bearing slide can be easily removed for replacement.
5. 100% open ball bearing slide.
6. Patented locking system. Pushing unlocked drawer to be locked while all others are locked.
7. Tool tray / side handle for easy lifting of roller wagon and can be holder for frequently used supplies.
8. 2 fixed caster + 2 swivel caster with brake.
9. 2mm protective drawer liners.
10. Powder coating finishing.
11. Two fixture on two sides, can be attached and hung other equipment.
12. Drawer are interchangeable.
13. Additional patented design one drawer open at a time locking system and shelf-closing ball bearing slide at your option.
14. Another drawer depth 410mm of W26 series for option.

**Steel thickness:**

Top and bottom cover: 1.2mm

Body: 1.0mm

Drawer: 1.0mm



**PAT. NO.**

- 216283(TW)
- 442053(CN)
- US 6347848 B1
- Nr. 20015566.0
- 205670(TW)
- 574422(CN)
- US 6742854 B2
- Nr.20215121.2
- M282635(TW)
- M264930(TW)
- 749238(CN)
- US 6896642 B1
- Nr.202004012437.8
- M274421(TW)
- 829087(CN)
- Nr.2020050131.28.8

One drawer open at a time locking system. When all of the drawers are locked, push the button to release the locked drawers.



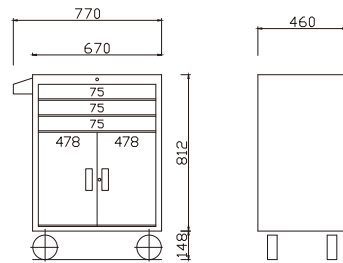

**W26-3KXL**

**3-Drawer Roll-Wagon  
With Bulk Storage Compartment  
Ball Bearing Slides**

	W	D	H	
Overall	26	18	31 7/8	in.
	670	460	812	mm
Overall	26	18	37 11/16	in.
With 5" Casters	670	460	960	mm
3 Drawers	22 5/8	15	2 15/16	in.
	576	380	75	mm
Panel Area	23 11/16	15	18 3/4	in.
	603	404	478	mm
<b>N.W.</b>	<b>G.W.</b>	<b>CUFT</b>		
47.2 KGS	54.2 KGS	12.24'		

**W26-3PX**

**3-Drawer Roll-Wagon  
With Bulk Storage Compartment  
Ball Bearing Slides**

	W	D	H	
Overall	26	18	25 11/16	in.
	670	460	650	mm
Overall	26	18	30 1/2	in.
With 4" Casters	670	460	773	mm
2 Drawers	22 5/8	15	2 15/16	in.
	576	380	75	mm
1 Drawers	22 5/8	15	6	in.
	576	380	154	mm
Panel Area	23 11/16	15 7/8	9 1/4	in.
	603	404	234	mm
<b>N.W.</b>	<b>G.W.</b>	<b>CUFT</b>		
43.4 KGS	50.4 KGS	10.03'		

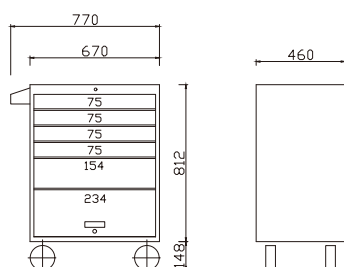
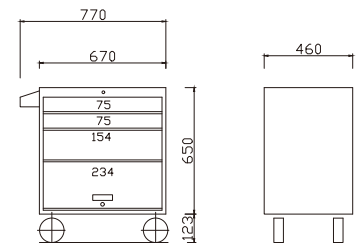

**W26-5PX**

**5-Drawer Roll-Wagon  
With Bulk Storage Compartment  
Ball Bearing Slides**

	W	D	H	
Overall	26	18	31 7/8	in.
	670	460	812	mm
Overall	26	18	37 11/16	in.
With 5" Casters	670	460	960	mm
4 Drawers	22 5/8	15	2 15/16	in.
	576	380	75	mm
1 Drawers	22 5/8	15	6	in.
	576	380	154	mm
Panel Area	23 11/16	15 7/8	9 1/4	in.
	603	404	234	mm
<b>N.W.</b>	<b>G.W.</b>	<b>CUFT</b>		
55.1 KGS	62.1 KGS	12.24'		



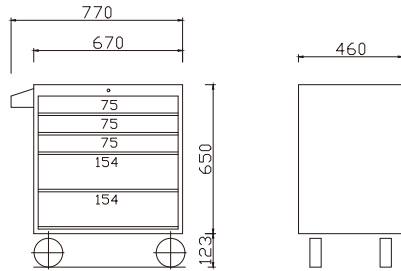

## W26-5X

### 5-Drawer Roll-Wagon

#### Ball Bearing Slides

	W	D	H	
Overall	26	18	25 11/16	in.
	670	460	650	mm
Overall	26	18	30 1/2	in.
With 4" Casters	670	460	773	mm
3 Drawers	22 5/8	15	2 15/16	in.
	576	380	75	mm
2 Drawers	22 5/8	15	6	in.
	576	380	154	mm
<b>N.W.</b>	<b>50.5 KGS</b>	<b>G.W.</b>	<b>57.5 KGS</b>	<b>CUFT</b>
				10.03'

## W26-6X

### 6-Drawer Roll-Wagon

#### Ball Bearing Slides

	W	D	H	
Overall	26	18	25 11/16	in.
	670	460	650	mm
Overall	26	18	30 1/2	in.
With 4" Casters	670	460	773	mm
5 Drawers	22 5/8	15	2 15/16	in.
	576	380	75	mm
1 Drawers	22 5/8	15	6	in.
	576	380	154	mm
<b>N.W.</b>	<b>54 KGS</b>	<b>G.W.</b>	<b>61 KGS</b>	<b>CUFT</b>
				10.03'

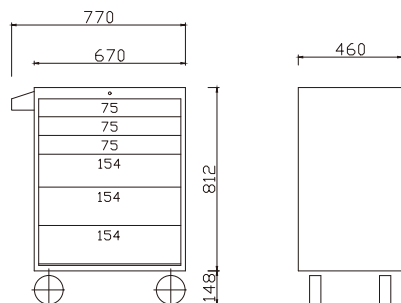
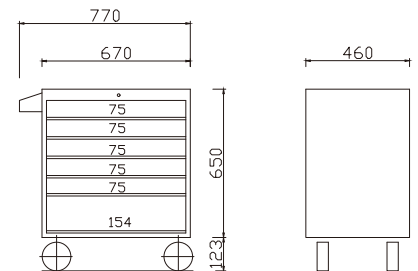

## W26-6XL

### 6-Drawer Roll-Wagon

#### Ball Bearing Slides

	W	D	H	
Overall	26	18	31 7/8	in.
	670	460	812	mm
Overall	26	18	37 11/16	in.
With 5" Casters	670	460	960	mm
3 Drawers	22 5/8	15	2 15/16	in.
	576	380	75	mm
3 Drawers	22 5/8	15	6	in.
	576	380	154	mm
<b>N.W.</b>	<b>62.7 KGS</b>	<b>G.W.</b>	<b>70.7 KGS</b>	<b>CUFT</b>
				12.24'

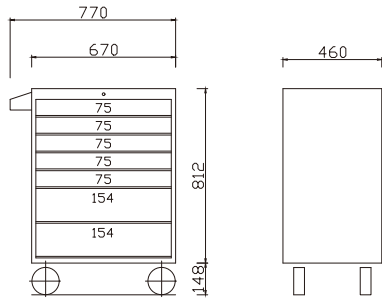

## W26-7X

### 7-Drawer Roll-Wagon

#### Ball Bearing Slides

	W	D	H	
Overall	26	18	31 7/8	in.
	670	460	812	mm
Overall	26	18	37 11/16	in.
With 5" Casters	670	460	960	mm
5 Drawers	22 5/8	15	2 15/16	in.
	576	380	75	mm
2 Drawers	22 5/8	15	6	in.
	576	380	154	mm
<b>N.W.</b>	<b>64 KGS</b>	<b>G.W.</b>	<b>72 KGS</b>	<b>CUFT</b>
				12.24'

## W26-8X

### 8-Drawer Roll-Wagon

#### Ball Bearing Slides

	W	D	H	
Overall	26	18	31 7/8	in.
	670	460	812	mm
Overall	26	18	37 11/16	in.
With 5" Casters	670	460	960	mm
7 Drawers	22 5/8	15	2 15/16	in.
	576	380	75	mm
1 Drawers	22 5/8	15	6	in.
	576	380	154	mm
<b>N.W.</b>	<b>66 KGS</b>	<b>G.W.</b>	<b>74 KGS</b>	<b>CUFT</b>
				12.24'

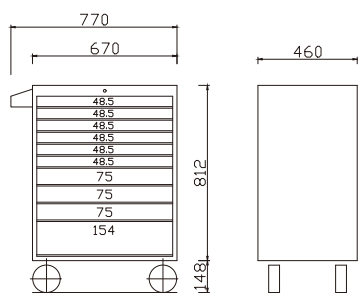
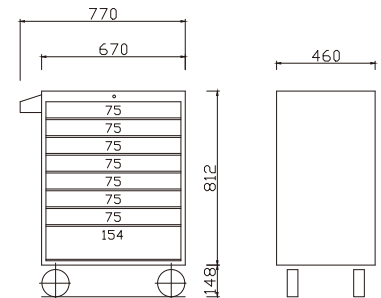

## W26-10X

### 10-Drawer Roll-Wagon

#### Ball Bearing Slides

	W	D	H	
Overall	26	18	31 7/8	in.
	670	460	812	mm
Overall	26	18	37 11/16	in.
With 5" Casters	670	460	960	mm
6 Drawers	22 5/8	15	1 7/8	in.
	576	380	48.5	mm
3 Drawers	22 5/8	15	2 15/16	in.
	576	380	75	mm
1 Drawers	22 5/8	15	6	in.
	576	380	154	mm
<b>N.W.</b>	<b>69 KGS</b>	<b>G.W.</b>	<b>76.5 KGS</b>	<b>CUFT</b>
				12.24'

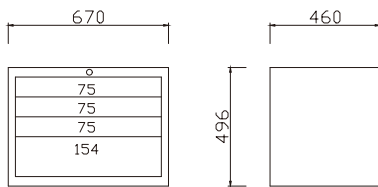

## W26-B4X 4-Drawer Roll-Wagon Ball Bearing Slides

	W	D	H	
Overall	26	18	19 1/2	in.
	670	460	496	mm
3 Drawers	22 5/8	15	2 15/16	in.
	576	380	75	mm
1 Drawers	22 5/8	15	6	in.
	576	380	154	mm
<b>N.W.</b>	<b>G.W.</b>	<b>CUFT</b>		
38.65 KGS	43.86 KGS	9.5'		



## W26-B4X-W 4-Drawer Roll-Wagon Ball Bearing Slides

	W	D	H	
Overall	26	18	19 1/2	in.
	670	460	496	mm
Overall With 4" Casters	26	18	25 5/16	in.
	670	460	619	mm
3 Drawers	22 5/8	15	24 3/8	in.
	576	380	75	mm
1 Drawers	22 5/8	15	6	in.
	576	380	154	mm
<b>N.W.</b>	<b>G.W.</b>	<b>CUFT</b>		
44.38 KGS	49.3 KGS	9.5'		

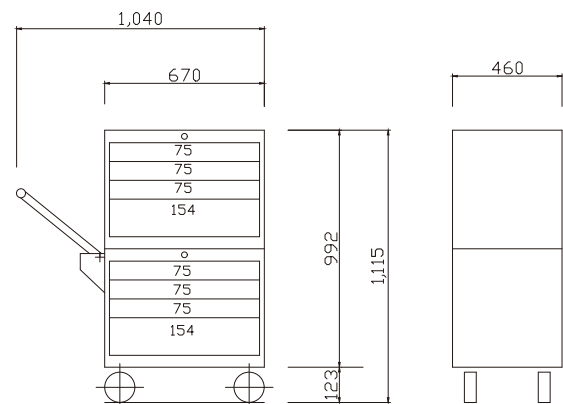
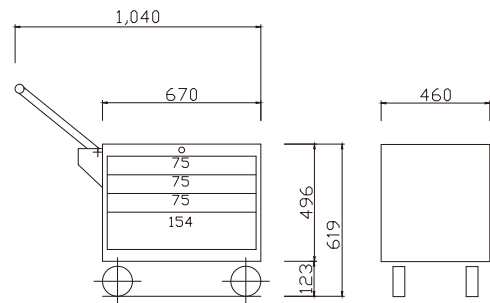



•It can hang on W26 Series, ET Series.

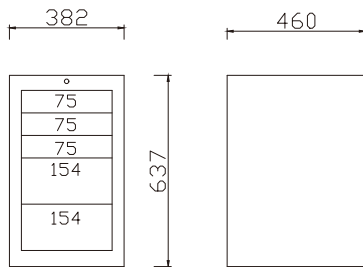

**W15-5X**  
5-Drawer Side-Cabinet  
Ball Bearing Slides

	W	D	H	
Overall	15	18	25	in.
	382	460	637	mm
3 Drawers	11 5/16	15	2 15/16	in.
	288	380	75	mm
2 Drawers	11 5/16	15	6	in.
	288	380	154	mm
<b>N.W.</b>	<b>G.W.</b>	<b>CUFT</b>		
33 KGS	38 KGS	6'		



•It can hang on W26 Series, ET Series.

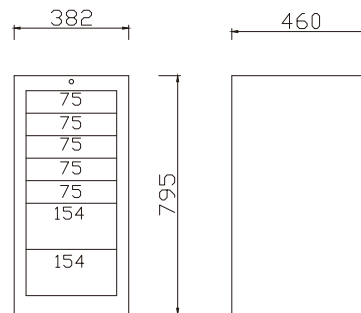

**W15-7X**  
7-Drawer Side-Cabinet  
Ball Bearing Slides

	W	D	H	
Overall	15	18	31 5/16	in.
	382	460	795	mm
5 Drawers	11 5/16	15	2 15/16	in.
	288	380	75	mm
2 Drawers	11 5/16	15	6	in.
	288	380	154	mm
<b>N.W.</b>	<b>G.W.</b>	<b>CUFT</b>		
41 KGS	47 KGS	8.5'		



•It can hang on W26 Series, ET Series.

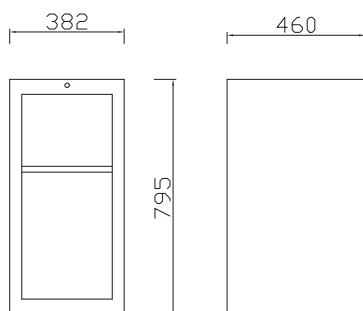

**W15-H7**  
Work Panel Side- Cabinet  
Ball Bearing Slide

	W	D	H	
Overall	15	18	31 5/16	in.
	382	460	795	mm
Panel Area	12 1/2	15 7/8	28	in.
	317.5	404	712	mm
<b>N.W.</b>	<b>G.W.</b>	<b>CUFT</b>		
28.4 KGS	35.4 KGS	7.5'		





**W15-S7**  
Side-Cabinet  
2 Shelf Cabinet

	W	D	H	
Overall	15	18	31 5/16	in.
	382	460	795	mm
Panel Area	12 1/2	17 5/16	27 7/8	in.
	316	440	709	mm
<b>N.W.</b>	<b>G.W.</b>	<b>CUFT</b>		
22.6 KGS	29.6 KGS	8.5'		

• It can hang on W26 Series, ET Series.

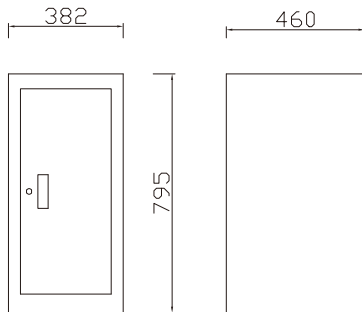

**W15-S3X**  
3-Drawer Side-Cabinet  
Ball Bearing Slides

	W	D	H	
Overall	15	18	15 3/4	in.
	382	460	400	mm
2 Drawers	11 5/16	15	2 15/16	in.
	288	380	75	mm
1 Drawers	11 5/16	15	6	in.
	288	380	154	mm
<b>N.W.</b>	<b>G.W.</b>	<b>CUFT</b>		
20.9 KGS	25.9 KGS	3.3'		

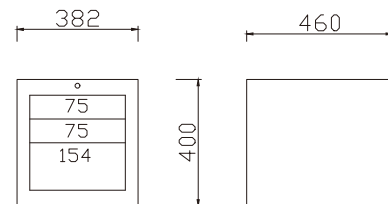

**W15-S4X**  
4-Drawer Side-Cabinet  
Ball Bearing Slides

	W	D	H	
Overall	15	18	15 3/4	in.
	382	460	400	mm
4 Drawers	11 5/16	15	2 15/16	in.
	288	380	75	mm
<b>N.W.</b>	<b>G.W.</b>	<b>CUFT</b>		
22.2 KGS	27.2 KGS	3.3'		

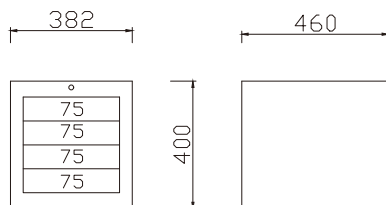

1. Patented standard divider design on the top lid storage allows changing storage spaces at your option.
2. Powder coating finishing.
3. Chest cover lid stay keeps cover from accidentally closing.
4. Hemed edge for body to add strength and safety.
5. Quick release design on ball bearing slide can be easily removed for replacement.
6. Drawer detent ( stopper ) prevent unintentional opening of drawer for replacement.
7. 100% open ball bearing slide.
8. Heavy duty side handles.
9. Alum. Extrusion drawer's handle with cardboard and PVC strips to list content of drawers.
10. Multiple numbers internal locking system for extra security.
11. 2mm Protective drawer liners.
12. " X " shape embossed at top and middle chests bottom provide better strength.
13. Rubber pads under the bottom of four corners prevent chests slip.
14. Drawers are interchangeable.
15. Additional option parts gas spring can be used on chest cover.

### Steel thickness:

Body: 0.8mm

Drawer: 0.7mm

Drop-front: 1.0mm



### PAT. NO.

122159(TW)  
310806(CN)  
218129(TW)  
581848(CN)  
Nr.20107252.1

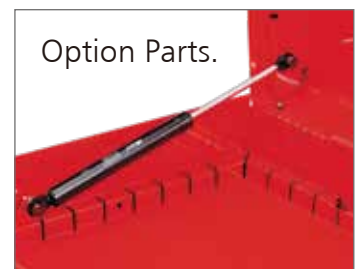
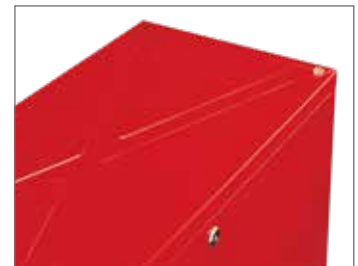

Option Parts.

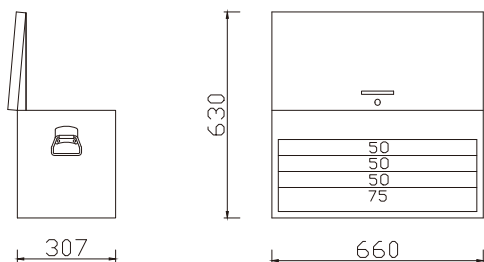

**EP222-4AX**  
4-Drawer A Type Top Chest  
Ball Bearing Slides

	W	D	H	
<b>Overall</b>	26	12	14 3/4	in.
	660	307	374	mm
<b>3 Drawers</b>	22 3/8	10 13/16	1 15/16	in.
	569	275	50	mm
<b>1 Drawers</b>	22 3/8	10 13/16	2 15/16	in.
	569	275	75	mm
<b>N.W.</b>	22.5 KGS	<b>G.W.</b>	25.5 KGS	<b>CUFT</b>
			4.2'	



**EP222-5AX**  
5-Drawer A Type Top Chest  
Ball Bearing Slides

	W	D	H	
<b>Overall</b>	26	12	16 13/16	in.
	660	307	427	mm
<b>4 Drawers</b>	22 3/8	10 13/16	1 15/16	in.
	569	275	50	mm
<b>1 Drawers</b>	22 3/8	10 13/16	2 15/16	in.
	569	275	75	mm
<b>N.W.</b>	25.5 KGS	<b>G.W.</b>	29.5 KGS	<b>CUFT</b>
			4.6'	

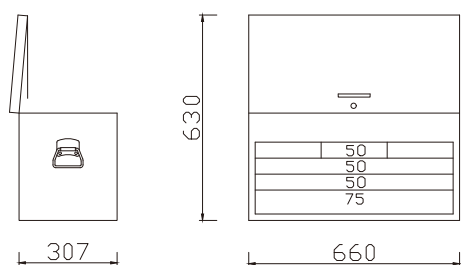
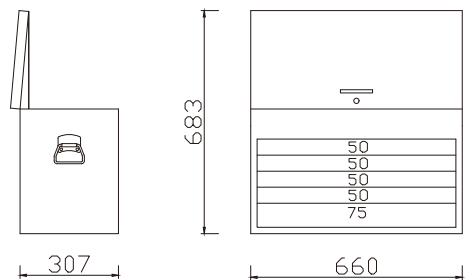

**EP222-6AX**  
6-Drawer A Type Top Chest  
Ball Bearing Slides

	W	D	H	
<b>Overall</b>	26	12	14 3/4	in.
	660	307	374	mm
<b>3 Drawers</b>	6 11/16	10 13/16	1 15/16	in.
	170	275	50	mm
<b>2 Drawers</b>	22 3/8	10 13/16	1 15/16	in.
	569	275	50	mm
<b>1 Drawers</b>	22 3/8	10 13/16	2 15/16	in.
	569	275	75	mm
<b>N.W.</b>	25.4 KGS	<b>G.W.</b>	28.4 KGS	<b>CUFT</b>
			4.2'	



**EP222-7AX**  
7-Drawer A Type Top Chest  
Ball Bearing Slides

	W	D	H	
<b>Overall</b>	26	12	16 13/16	in.
	660	307	427	mm
<b>3 Drawers</b>	6 11/16	10 13/16	1 15/16	in.
	170	275	50	mm
<b>3 Drawers</b>	22 3/8	10 13/16	1 15/16	in.
	569	275	50	mm
<b>1 Drawers</b>	22 3/8	10 13/16	2 15/16	in.
	569	275	75	mm
<b>N.W.</b>	<b>G.W.</b>	<b>CUFT</b>		
28.3 KGS	32.3 KGS	4.6'		

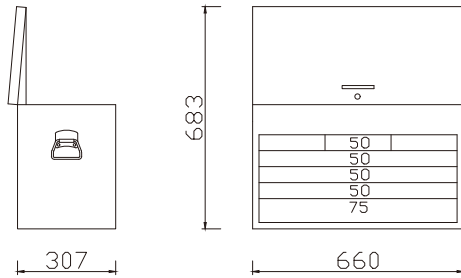

**EP222-9AX**  
9-Drawer A Type Top Chest  
Ball Bearing Slides

	W	D	H	
<b>Overall</b>	26	12 1/16	16 13/14	in.
	660	307	427	mm
<b>6 Drawers</b>	6 11/16	10 13/16	1 15/16	in.
	170	275	50	mm
<b>2 Drawers</b>	22 3/8	10 13/16	1 15/16	in.
	569	275	50	mm
<b>1 Drawers</b>	22 3/8	10 13/16	2 15/16	in.
	569	275	75	mm
<b>N.W.</b>	<b>G.W.</b>	<b>CUFT</b>		
30.2 KGS	34.2 KGS	4.6'		

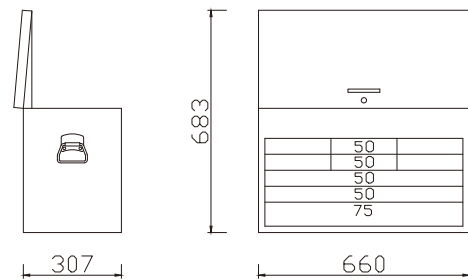



1. Patented standard divider design on the top lid storage allows changing storage spaces at your option.
2. Powder coating finishing.
3. Chest cover lid stay keeps cover from accidentally closing.
4. Hemmed edge for body to add strength and safety.
5. Quick release design on ball bearing slide can be easily removed for replacement.
6. Drawer detent ( stopper ) prevent unintentional opening of drawer.
7. 100% open ball bearing slide.
8. Heavy duty side handles.
9. Alum. Extrusion drawer's handle with cardboard and PVC strips to list content of drawers.
10. Multiple numbers internal locking system for extra security.
11. 2mm Protective drawer liners.
12. " X" shape embossed at top and middle chests bottom provide better strength.
13. Rubber pads under the bottom of four corners prevent chests from slip.
14. Chest cover automatically locks drawer when cover is closed.
15. Drawer are interchangeable.
16. Additional option parts gas spring can be used on chest cover.

**Steel thickness:**

Body: 0.8mm

Drawer: 0.7mm



## EP222-4BX

4-Drawer B Type Top Chest  
Ball Bearing Slides

	W	D	H	
<b>Overall</b>	26	12	14 11/16	in.
	660	307	374	mm
<b>3 Drawers</b>	22 3/8	10 13/16	1 15/16	in.
	569	275	50	mm
<b>1 Drawers</b>	22 3/8	10 13/16	2 15/16	in.
	569	275	75	mm
	<b>N.W.</b>	<b>G.W.</b>	<b>CUFT</b>	
	21 KGS	24 KGS	4.2'	

**PAT. NO.**

122159(TW)  
310806(CN)  
218129(TW)  
581848(CN)  
Nr.20107252.1

M264348(TW)  
734220(CN)  
US 7264319 B2  
Nr.202005006783.0

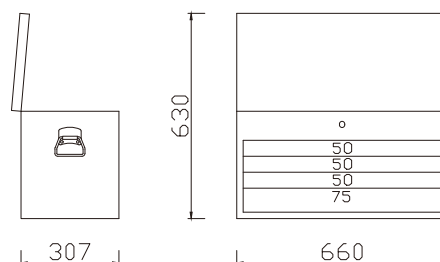



**EP222-5BX**  
5-Drawer B Type Top Chest  
Ball Bearing Slides

	W	D	H	
<b>Overall</b>	26	18	16 13/16	in.
	660	307	427	mm
<b>4 Drawers</b>	22 3/8	10 13/16	1 15/16	in.
	569	275	50	mm
<b>1 Drawers</b>	22 3/8	10 13/16	2 15/16	in.
	569	275	75	mm
	<b>N.W.</b>	<b>G.W.</b>	<b>CUFT</b>	
	23.7 KGS	27.7 KGS	4.6'	

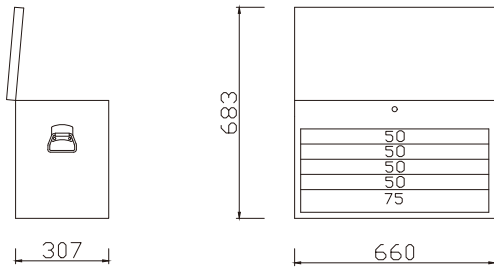

**EP222-6BX**  
6-Drawer B Type Top Chest  
Ball Bearing Slides

	W	D	H	
<b>Overall</b>	26	12	14 11/16	in.
	660	307	374	mm
<b>3 Drawers</b>	6 11/16	10 13/16	1 15/16	in.
	170	275	50	mm
<b>2 Drawers</b>	22 3/8	10 13/16	1 15/16	in.
	569	275	50	mm
<b>1 Drawers</b>	22 3/8	10 13/16	2 15/16	in.
	569	275	75	mm
	<b>N.W.</b>	<b>G.W.</b>	<b>CUFT</b>	
	23.5 KGS	25.1 KGS	4.2'	

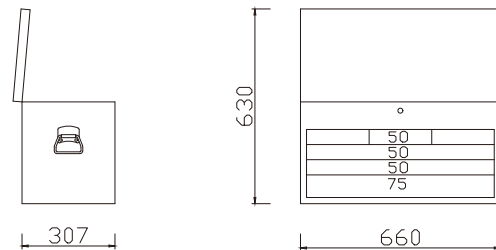

**EP222-7BX**  
7-Drawer B Type Top Chest  
Ball Bearing Slides

	W	D	H	
<b>Overall</b>	26	12	16 13/16	in.
	660	307	427	mm
<b>3 Drawers</b>	6 3/4	10 13/16	1 15/16	in.
	170	275	50	mm
<b>3 Drawers</b>	22 3/8	10 13/16	1 15/16	in.
	569	275	50	mm
<b>1 Drawers</b>	22 3/8	10 13/16	2 15/16	in.
	569	275	75	mm
	<b>N.W.</b>	<b>G.W.</b>	<b>CUFT</b>	
	26.5 KGS	30.5 KGS	4.6'	

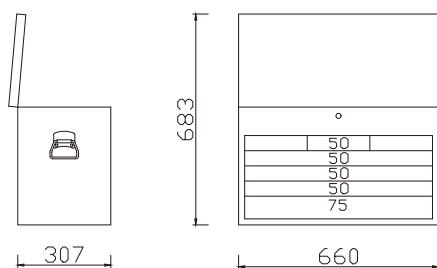

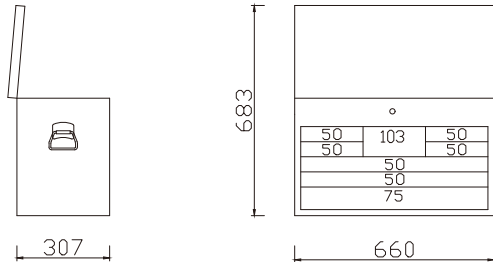

**EP222-8BX**

**8-Drawer B Type Top Chest**  
Ball Bearing Slides

	W	D	H	
<b>Overall</b>	26	12	16 13/16	in.
	660	307	427	mm
<b>4 Drawers</b>	6 11/16	10 13/16	1 15/16	in.
	170	275	50	mm
<b>1 Drawers</b>	6 11/16	10 13/16	4 1/16	in.
	170	275	103	mm
<b>2 Drawers</b>	22 3/8	10 13/16	1 15/16	in.
	569	275	50	mm
<b>1 Drawers</b>	22 3/8	10 13/16	2 15/16	in.
	569	275	75	mm
<b>N.W.</b>	26.5 KGS	<b>G.W.</b>	28.8 KGS	<b>CUFT</b>
			4.6'	

**EP222-9BX**

**9-Drawer B Type Top Chest**  
Ball Bearing Slides

	W	D	H	
<b>Overall</b>	26	12	16 13/16	in.
	660	307	427	mm
<b>6 Drawers</b>	6 11/16	10 13/16	1 15/16	in.
	170	275	50	mm
<b>2 Drawers</b>	22 3/8	10 13/16	1 15/16	in.
	569	275	50	mm
<b>1 Drawers</b>	22 3/8	10 13/16	1 15/16	in.
	569	275	75	mm
<b>N.W.</b>	27.1 KGS	<b>G.W.</b>	29.4 KGS	<b>CUFT</b>
			4.6'	

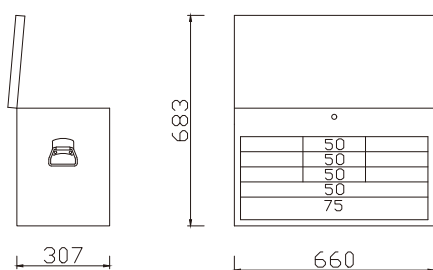
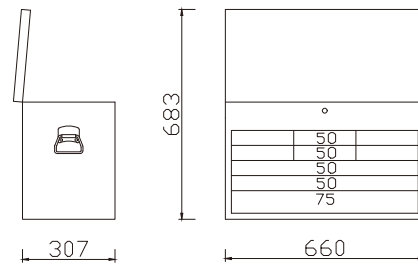

**EP222-11BX**

**11-Drawer B Type Top Chest**  
Ball Bearing Slides

	W	D	H	
<b>Overall</b>	26	12	16 13/16	in.
	660	307	427	mm
<b>9 Drawers</b>	6 11/16	10 13/16	1 15/16	in.
	170	275	50	mm
<b>1 Drawers</b>	22 3/8	10 13/16	1 15/16	in.
	569	275	50	mm
<b>1 Drawers</b>	22 3/8	10 13/16	2 15/16	in.
	569	275	75	mm
<b>N.W.</b>	28.9 KGS	<b>G.W.</b>	31.3 KGS	<b>CUFT</b>
			4.6'	

1. Alum Extrusion drawer's handle with cardboard and PVC strips to list contents of drawers.
2. Four pins on the four corners of middle chest fasten top chest prevent from moving.
3. 12mm protective mat on the top of the chest.
4. Heavy duty side handles.
5. Powder coating finishing.
6. 2mm protective drawer liners.
7. Multiple numbers internal locking system for extra security.
8. Quick release design on ball bearing slide can be easily removed for replacement.
9. Drawer detent (stopper) prevent unintentional opening of drawer.
10. 100% open ball bearing slide.
11. "X" shape embossed at top and middle chests bottom provide better strength.
12. Rubber pod under the bottom of four corners prevent chest slip.

**Steel thickness:**

Body: 0.8mm

Drawer: 0.7mm





**I-3X**

**3-Drawer Intermediate Chest  
Ball Bearing Slides**

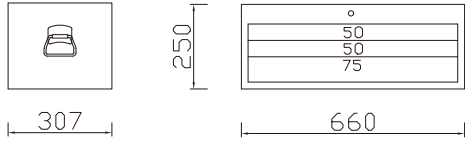

	W	D	H	
<b>Overall</b>	26	12	9 7/8	in.
	660	307	250	mm
<b>2 Drawers</b>	22 3/8	10 13/16	1 15/16	in.
	569	275	50	mm
<b>1 Drawers</b>	22 3/8	10 13/16	2 15/16	in.
	569	275	75	mm
	<b>N.W.</b>	<b>G.W.</b>	<b>CUFT</b>	
	14.5KGS	16.1 KGS	2.7'	

Steel thickness:  
Body: 0.8mm  
Drawer: 0.7mm



FULL SIZE MIDDLE CHEST

**EP333-I-3X**

**3-Drawer Full Size Middle Chest  
Ball Bearing Slides**

	W	D	H	
<b>Overall</b>	26	17 15/16	10	in.
	660	455	254	mm
<b>2 Drawers</b>	22 5/8	16 1/8	1 7/8	in.
	576	410	48.5	mm
<b>1 Drawers</b>	22 5/8	16 1/8	2 15/16	in.
	576	410	75	mm
	<b>N.W.</b>	<b>G.W.</b>	<b>CUFT</b>	
	24.8 KGS	27.1 KGS	5'	

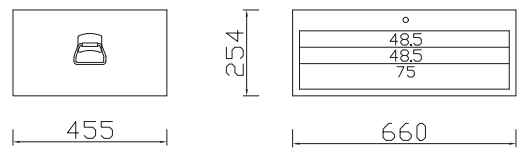

Steel thickness:  
Body: 1.2mm  
Drawer: 1.0mm

1. Powder coating finishing.
2. All series equipped with gas spring cylinder for safety and accessibility.
3. Chest cover automatically locks drawer when cover is closed.
4. Quick release design on ball bearing slide can be easily removed for replacement.
5. Drawer detent ( stopper ) prevent unintentional opening of drawer for replacement.
6. Hemed edge for body to add strength and safety.
7. Heavy duty side handles.
8. Alum. Extrusion drawer's handle with cardboard and PVC strips to list content of drawers.
9. Multiple numbers internal locking system for extra security.
10. 2mm Protective drawer liners.
11. Chest cover automatically locks drawer when cover is closed.

**Steel thickness:**

Top and bottom covers: 1.0mm

Body: 1.2mm

Drawer: 1.0mm

Drop-front: 1.0mm



## EP333-5AX

5-Drawer Full Size A Type Top Chest  
Ball Bearing Slides  
The Cover with Gas Spring

	W	D	H	
<b>Overall</b>	26	17 15/16	19	in.
	660	455	483	mm
<b>2 Drawers</b>	22 5/8	16 1/8	1 7/8	in.
	576	410	48.5	mm
<b>3 Drawers</b>	22 5/8	16 1/8	2 15/16	in.
	576	410	75	mm
	<b>N.W.</b>	<b>G.W.</b>	<b>CUFT</b>	
	41.6 KGS	50.6 KGS	8.58'	

**PAT. NO.**

218129(TW)  
581848(CN)  
Nr.20107252.1

M264348(TW)  
734220(CN)  
US 7264319 B2  
Nr.202005006783.0

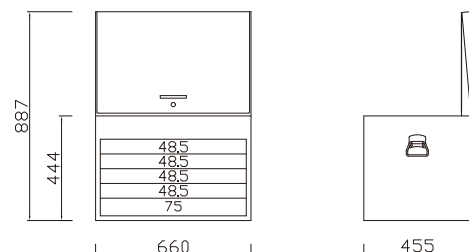

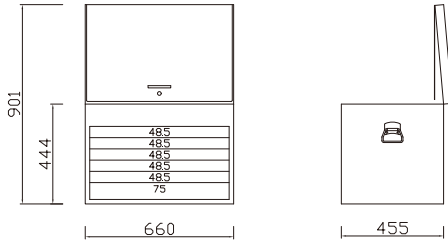

**EP333-6AX**

6-Drawer Full Size A Type Top Chest  
Ball Bearing Slides  
The Cover with Gas Spring

	W	D	H	
Overall	26	17 15/16	19	in.
	660	455	483	mm
5 Drawers	22 5/8	16 1/8	1 7/8	in.
	576	410	48.5	mm
1 Drawers	22 5/8	16 1/8	2 15/16	in.
	576	410	75	mm
<b>N.W.</b>	<b>G.W.</b>	<b>CUFT</b>		
48.1 KGS	54.1 KGS	8.58'		

**EP333-10AX**

10-Drawer Full Size A Type Top Chest  
Ball Bearing Slides  
The Cover with Gas Spring

	W	D	H	
Overall	26	17 15/16	19	in.
	660	455	483	mm
6 Drawers	6 5/8	16 1/8	1 7/8	in.
	169	410	48.5	mm
1 Drawers	6 5/8	16 1/8	6	in.
	169	410	154	mm
2 Drawers	22 5/8	16 1/8	1 7/8	in.
	576	410	48.5	mm
1 Drawers	22 5/8	16 1/8	2 15/16	in.
	576	410	75	mm
<b>N.W.</b>	<b>G.W.</b>	<b>CUFT</b>		
52.8 KGS	56.8 KGS	8.58'		

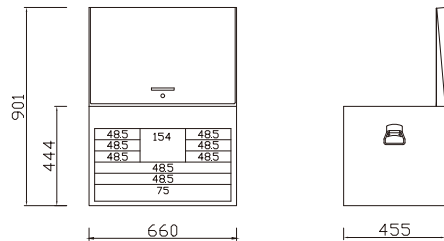

**EP333-12AX**

12-Drawer Full Size A Type Top Chest  
Ball Bearing Slides  
The Cover with Gas Spring

	W	D	H	
Overall	26	17 15/16	19	in.
	660	455	483	mm
9 Drawers	6 5/8	16 1/8	1 7/8	in.
	169	410	48.5	mm
2 Drawers	22 5/8	16 1/8	1 7/8	in.
	576	410	48.5	mm
1 Drawers	22 5/8	16 1/8	2 15/16	in.
	576	410	75	mm
<b>N.W.</b>	<b>G.W.</b>	<b>CUFT</b>		
56.8 KGS	60.8 KGS	8.58'		

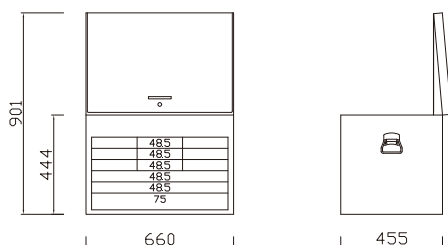



**EP333-5BX**

5-Drawer Full Size B Type Top Chest  
Ball Bearing Slides  
The Cover with Gas Spring

	W	D	H	
Overall	26	17 15/16	19	in.
	660	455	483	mm
2 Drawers	22 5/8	16 1/8	1 7/8	in.
	576	410	48.5	mm
3 Drawers	22 5/8	16 1/8	2 15/16	in.
	576	410	75	mm
	<b>N.W.</b>	<b>G.W.</b>	<b>CUFT</b>	
	40 KGS	49 KGS	8.58'	

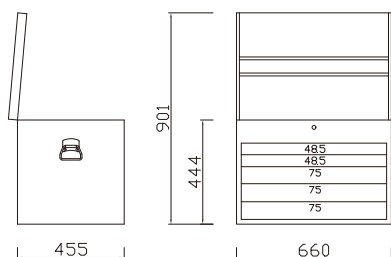

**EP333-6BX**

6-Drawer Full Size B Type Top Chest  
Ball Bearing Slides  
The Cover with Gas Spring

	W	D	H	
Overall	26	17 15/16	19	in.
	660	455	483	mm
5 Drawers	22 5/8	16 1/8	1 7/8	in.
	576	410	48.5	mm
1 Drawers	22 5/8	16 1/8	2 15/16	in.
	576	410	75	mm
	<b>N.W.</b>	<b>G.W.</b>	<b>CUFT</b>	
	45.6 KGS	49.6 KGS	8.58'	

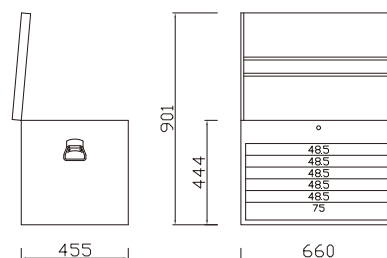





**EP333-10BX**  
 10-Drawer Full Size B Type  
 Ball Bearing Slides  
 The Cover with Gas Spring

	W	D	H	
<b>Overall</b>	26	17 15/16	19	in.
	660	455	483	mm
<b>6 Drawers</b>	6 5/8	16 1/8	1 7/8	in.
	169	410	48.5	mm
<b>1 Drawers</b>	6 5/8	16 1/8	6	in.
	169	410	154	mm
<b>2 Drawers</b>	22 5/8	16 1/8	1 7/8	in.
	576	410	48.5	mm
<b>1 Drawers</b>	22 5/8	16 1/8	2 15/16	in.
	576	410	75	mm
<b>N.W.</b>	<b>G.W.</b>	<b>CUFT</b>		
50.1 KGS	55.1 KGS	8.58'		

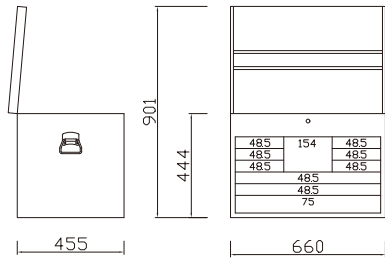

**EP333-12BX**  
 12-Drawer Full Size B Type Top Chest  
 Ball Bearing Slides  
 The Cover with Gas Spring

	W	D	H	
<b>Overall</b>	26	17 15/16	19	in.
	660	455	483	mm
<b>9 Drawers</b>	6 5/8	16 1/8	1 7/8	in.
	169	410	48.5	mm
<b>2 Drawers</b>	22 5/8	16 1/8	1 7/8	in.
	576	410	48.5	mm
<b>1 Drawers</b>	22 5/8	16 1/8	2 15/16	in.
	576	410	75	mm
<b>N.W.</b>	<b>G.W.</b>	<b>CUFT</b>		
54.2 KGS	58.2 KGS	8.58'		

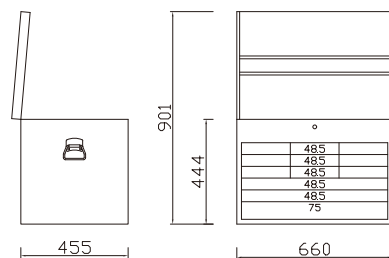

1. 4 pillars with patent clamp insert heavy duty design, assembly easily.
2. All series equipped with gas spring cylinder for safety and accessibility.
3. Aluminum extrusion drawer's handle with cardboard and PVC strips to list content of drawers.
4. Multiple numbers internal locking system for extra security.
5. Patented locking system, pushing unlocked drawer to be locked while all others are locked.
6. Quick release design on ball bearing slide can be easily removed for replacement.
7. 2mm protective drawer liners.
8. 2mm protective liners for top and bottom shelves.
9. Drawer detent (stopper) prevent unintentional opening of drawer.
10. Powder coating finishing.

**Steel thickness:**

The covers: 1.8mm

Body: 1.0mm

Drawer: 1.0mm

Pillar: 2.0mm

**PAT. NO.**

174891(TW)  
 390245(CN)  
 214005(TW)  
 586491(CN)  
 US 6572203 B1  
 Nr.20211084.2

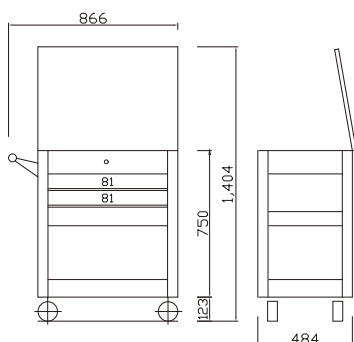

**ET302**

2-Drawer Service Cart  
 Ball Bearing Slides  
 The Cover with Gas Spring

	W	D	H	
Overall	30	19 1/4	29 11/16	in.
	780	520	754	mm
Overall	30	19 1/4	34 3/4	in.
With 4" Casters	780	520	884	mm
2 Drawers	24 11/16	17 1/2	3 3/16	in.
	628	445	81	mm
<b>N.W.</b>	<b>G.W.</b>	<b>CUFT</b>		
44 KGS	47 KGS	6.92'		



**ET303**

**3-Drawer Service Cart  
Ball Bearing Slides  
The Cover with Gas Spring**

	W	D	H	
<b>Overall</b>	30	19 1/4	29 11/16	in.
	780	520	754	mm
<b>Overall</b>	30	19 1/4	34 3/4	in.
<b>With 4" Casters</b>	780	520	884	mm
<b>2 Drawers</b>	11 11/16	17 1/2	3 3/16	in.
	298	445	81	mm
<b>1 Drawers</b>	24 11/16	17 1/2	3 3/16	in.
	628	445	81	mm
	<b>N.W.</b>	<b>G.W.</b>	<b>CUFT</b>	
	49 KGS	53.4 KGS	8.7'	

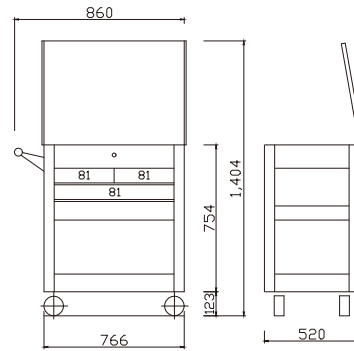

**ET303L**

**3-Drawer Service Cart  
Ball Bearing Slides  
The Cover with Gas Spring**

	W	D	H	
<b>Overall</b>	30	19 1/4	35	in.
	780	520	890	mm
<b>Overall</b>	30	19 1/4	40 1/4	in.
<b>With 4" Casters</b>	780	520	1020	mm
<b>2 Drawers</b>	24 11/16	17 1/2	3 3/16	in.
	628	445	81	mm
<b>1 Drawers</b>	24 11/16	17 1/2	5	in.
	628	445	127	mm
	<b>N.W.</b>	<b>G.W.</b>	<b>CUFT</b>	
	55 KGS	60 KGS	10.82'	

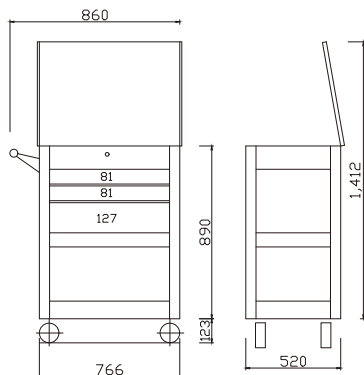



**ET304**  
**4-Drawer Service Cart**  
**Ball Bearing Slides**  
**The Cover with Gas Spring**

	W	D	H	
<b>Overall</b>	30	19 1/4	35	in.
	780	520	890	mm
<b>Overall</b>	30	19 1/4	40 1/4	in.
<b>With 4" Casters</b>	780	520	1020	mm
<b>2 Drawers</b>	11 11/16	17 1/2	3 3/16	in.
	298	445	81	mm
<b>1 Drawers</b>	24 11/16	17 1/2	3 3/16	in.
	628	445	81	mm
<b>1 Drawers</b>	24 11/16	17 1/2	5	in.
	628	445	127	mm
	<b>N.W.</b>	<b>G.W.</b>	<b>CUFT</b>	
	60 KGS	65 KGS	10.82'	

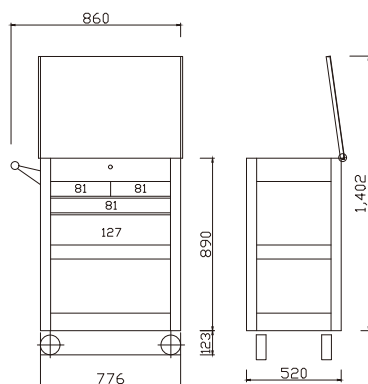

**ET300-TL1**  
**3 Shelf Trolley With 44 pcs BT40**

	W	D	H	
<b>Overall</b>	30 1/8	19 1/4	37 3/8	in.
	766	490	957	mm
<b>Overall</b>	30 1/8	19 1/4	44 5/8	in.
<b>With 5" Casters</b>	766	490	1134	mm
	<b>N.W.</b>	<b>G.W.</b>	<b>CUFT</b>	
	34.4 KGS	38.4 KGS	6.5'	

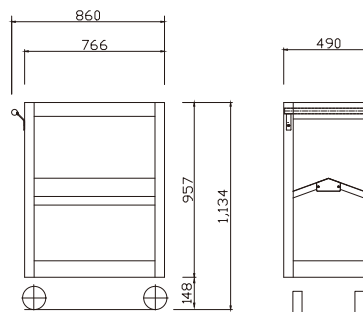



1. 4 pillars with patent clamp insert heavy duty design, assembly easily.
2. 2mm protective liners for top and bottom and middle shelves.
3. 2mm protective drawer liners.
4. Aluminum extrusion drawer's handle with cardboard and PVC strips to list content of drawers.
5. Powder coating finishing.
6. Multiple numbers internal locking system for extra security.
7. Quick release design on ball bearing slide can be easily removed for replacement.
8. Drawer detent ( stopper ) prevent unintentional opening of drawer.
9. 100% open ball bearing slide.

**Steel thickness:**

Pillar: 1.5mm

Shelf: 1.0mm

Drawer: 0.7mm

**PAT. NO.**

**174891(TW)**

**390245(CN)**



## T28 3 Shelf Trolley

	W	D	H	
Overall	28	16 1/8	29 1/2	in.
	716	410	750	mm
Overall With 4" Casters	28	16 1/8	34 5/8	in.
	716	410	880	mm
	<b>N.W.</b>	<b>G.W.</b>	<b>CUFT</b>	
	20.2 KGS	22.2 KGS	2.7'	

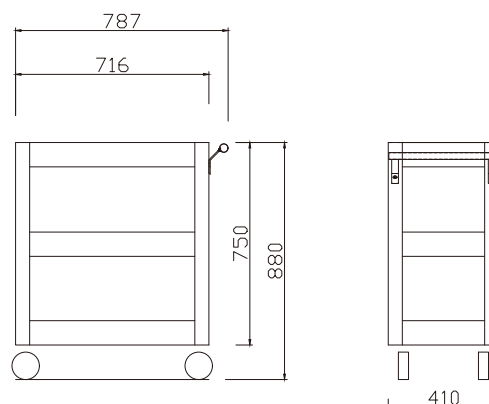



**T28-1X**  
1-Drawer Trolley  
Ball Bearing Slides

	W	D	H	
Overall	28	19 1/8	29 1/2	in.
	716	410	750	mm
Overall	28	16 1/8	34 5/8	in.
With 4" Casters	716	410	880	mm
1 Drawers	22 3/8	10 13/16	1 15/16	in.
	569	275	75	mm
<b>N.W.</b>	<b>G.W.</b>	<b>CUFT</b>		
23.2 KGS	24.6 KGS	2.7'		

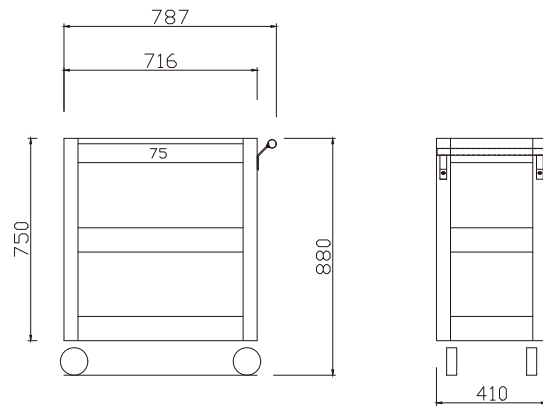

**T28-3X**  
3-Drawer Trolley  
Ball Bearing Slides

	W	D	H	
Overall	28	16 1/8	29 1/2	in.
	716	410	750	mm
Overall	28	16 1/8	34 5/8	in.
With 4" Casters	716	410	880	mm
2 Drawers	22 3/8	10 13/16	1 15/16	in.
	569	275	50	mm
1 Drawers	22 3/8	10 13/16	2 15/16	in.
	569	275	75	mm
<b>N.W.</b>	<b>G.W.</b>	<b>CUFT</b>		
33 KGS	34.5 KGS	4.95'		

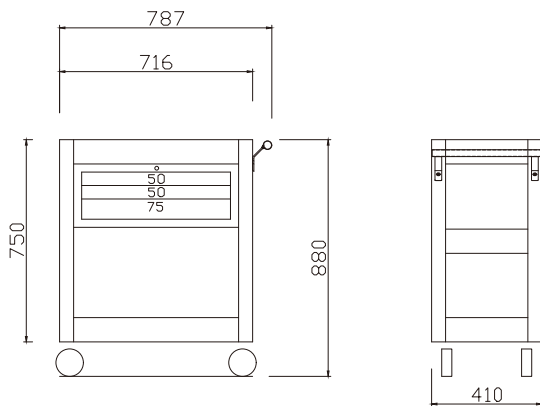

1. Multiple numbers internal locking system for extra security.
2. Heavy duty loaded up to 1000 kgs, optional 6mm P.P. impacting board (AC-CB) to protect table top.
3. 2mm thickness of square pillar heavy duty structure.
4. 4 adjustable leveling legs (AC-ADJ), adjust height and level.
5. Powder coating finishing.
6. Quick release design on ball bearing slide can be easily removed for replacement.
7. Drawer detent (stopper) prevent unintentional opening of drawer.
8. 100% open ball bearing slide.

#### Steel thickness:

Wall Cabinet: 1.0mm

Workbench: 2.0mm

Drawer: 0.7mm

Backpanel: 1.0mm

Pillar: 2.0mm

**PAT. NO.**

**075202(TW)**

**US D466717 S**



## WB59-A Workbench



	W	D	H	
Overall	60	27 1/2	31 1/2	in.
	1525	700	800	mm
<b>N.W.</b>	<b>G.W.</b>	<b>CUFT</b>		
46.6 KGS	49.5 KGS	6.5'		

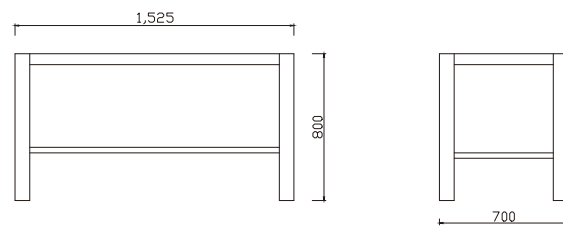

## WB59-B

WB59-A With 3-Drawer Chest  
Ball Bearing Slides

	W	D	H	
Overall	60	27 1/2	31 1/2	in.
	1525	700	800	mm
3-Drawer	26	12	9 7/8	in.
Chest	660	307	250	mm
2 Drawers	22 3/8	10 13/16	1 15/16	in.
	569	275	50	mm
1 Drawers	22 3/8	10 13/16	2 15/16	in.
	569	275	75	mm
<b>N.W.</b>	<b>G.W.</b>	<b>CUFT</b>		
Box 1 of 2	46.6 KGS	49.5 KGS	6.5'	
Box 2 of 2	14.5 KGS	16 KGS	2.7'	

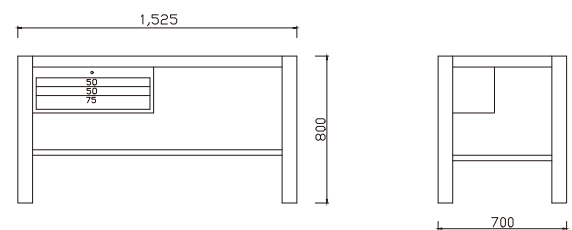





## WB59-C

WB59-A With Backpanel

	W	D	H	
Overall	60	27 1/2	49 1/2	in.
	1525	700	1520	mm
Backpanel	60	13/16	27 1/2	in.
	1525	20	700	mm
<b>N.W.</b>		<b>G.W.</b>	<b>CUFT</b>	
61.9 KGS		63.9 KGS	6.5'	

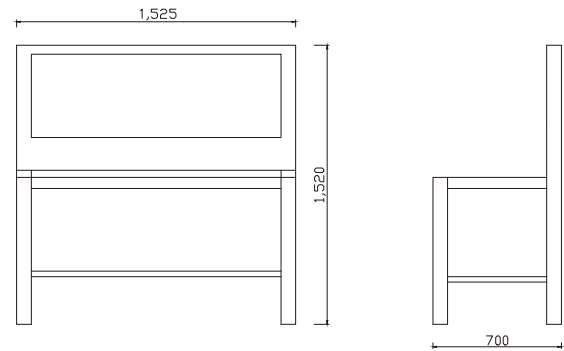

## WB59-D

WB59-C With 3-Drawer Chest  
Ball Bearing Slides

	W	D	H	
Overall	60	27 1/2	49 1/2	in.
	1525	700	1520	mm
Backpanel	60	13/16	27 1/2	in.
	1525	20	700	mm
3-Drawer	26	12	9 7/8	in.
Chest	660	307	250	mm
2 Drawers	22 3/8	10 13/16	1 15/16	in.
	569	275	50	mm
1 Drawers	22 3/8	10 13/16	2 15/16	in.
	569	275	75	mm
<b>N.W.</b>		<b>G.W.</b>	<b>CUFT</b>	
Box 1 of 2		61.9 KGS	63.9 KGS	6.5'
Box 2 of 2		14.5 KGS	16 KGS	2.7'

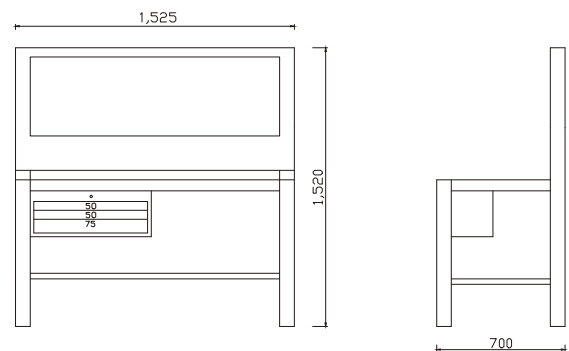



## WB59-E

WB59-C With 2 Wall Cabinet

	W	D	H	
Overall	60	27 1/2	49 1/2	in.
	1525	700	1520	mm
Backpanel	60	13/16	27 1/2	in.
	1525	20	700	mm
2 Wall	15 11/15	7 13/16	19 5/8	in.
Cabinet	400	200	500	mm
	<b>N.W.</b>	<b>G.W.</b>	<b>CUFT</b>	
Box 1 of 2	61.9 KGS	63.9 KGS	6.5'	
Box 2 of 2	14 KGS	15.4 KGS	4.5'	

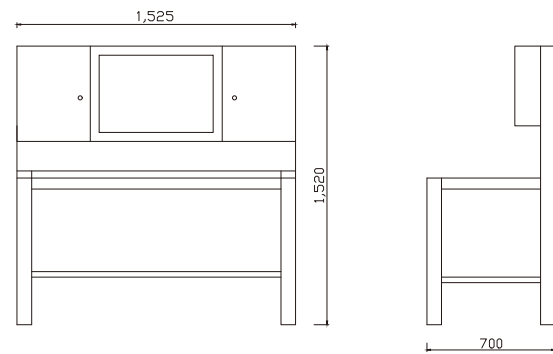

## WB59-F

WB59-E With 3-Drawer Chest  
Ball Bearing Slides

	W	D	H	
Overall	60	27 1/2	49 1/2	in.
	1525	700	1520	mm
Backpanel	60	13/16	27 1/2	in.
	1525	20	700	mm
2 Wall	15 11/16	7 13/16	19 5/8	in.
Cabinet	400	200	500	mm
3 Drawer	26	12	9 7/8	in.
Chest	660	307	250	mm
2 Drawers	22 3/8	10 13/16	1 15/16	in.
	569	275	50	mm
1 Drawer	22 3/8	10 13/16	2 15/16	in.
	569	275	75	mm
	<b>N.W.</b>	<b>G.W.</b>	<b>CUFT</b>	
Box 1 of 2	61.9 KGS	63.9 KGS	6.5'	
Box 2 of 2	32.2 KGS	35.2 KGS	8'	

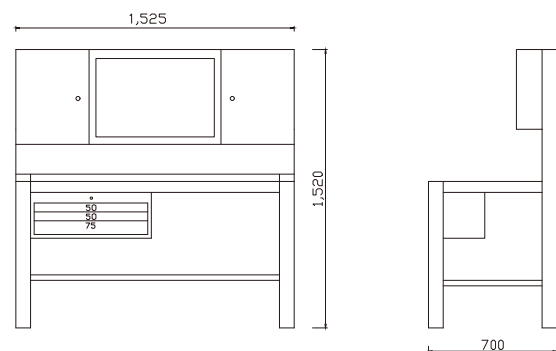

1. 100 numbers internal locking system for extra security.
2. Heavy duty loaded up to 500 kgs, optional 6mm P.P. impacting board (AC-CB) to protect table top.
3. 1 mm thickness of square pillar heavy duty structure.
4. 4 adjustable leveling legs (AC-ADJ), adjust height and level.
5. Powder coating finishing.
6. Quick release design on ball bearing slide can be easily removed for replacement.
7. Drawer detent (stopper) prevent unintentional opening of drawer.
8. 100% open ball bearing slide.

Steel thickness:

Wall Cabinet: 1.0mm

Workbench: 1.0mm

Drawer: 0.7mm

Backpanel: 1.0mm

Pillar: 1.5mm



## WB50E-A Workbench

	W	D	H	
Overall	50	27 1/2	31 1/2	in.
	1260	700	800	mm
	<b>N.W.</b>	<b>G.W.</b>	<b>CUFT</b>	
	27.6 KGS	30.6 KGS	6'	

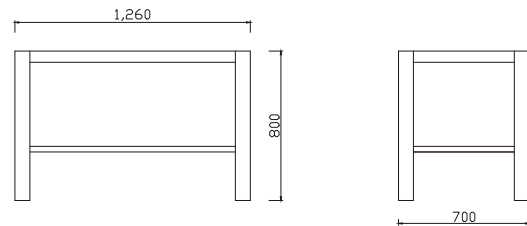

## WB50E-B

WB50E-A With 3-Drawer Chest  
Ball Bearing Slides

	W	D	H	
Overall	50	27 1/2	31 1/2	in.
	1260	700	800	mm
3 Drawer	26	12	9 7/8	in.
Chest	660	307	250	mm
2 Drawers	22 3/8	10 13/16	1 15/16	in.
	569	275	50	mm
1 Drawer	22 3/8	10 13/16	2 15/16	in.
	569	275	75	mm
	<b>N.W.</b>	<b>G.W.</b>	<b>CUFT</b>	
Box 1 of 2	27.6 KGS	30.6 KGS	6'	
Box 2 of 2	14.5 KGS	16.1 KGS	2.7'	

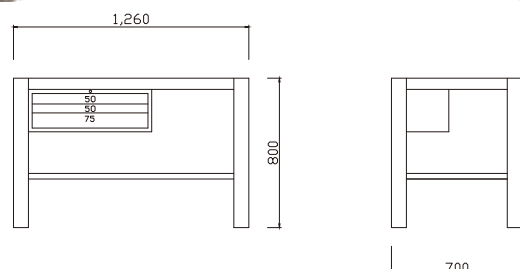



**WB50E-C**

WB50E-A With Backpanel

	W	D	H	
<b>Overall</b>	50	27 1/2	49 1/2	in.
	1260	700	1520	mm
<b>Backpanel</b>	50	13/16	27 1/2	in.
	1260	20	700	mm
<b>N.W.</b>	41 KGS	<b>G.W.</b>	44 KGS	<b>CUFT</b>
			6'	

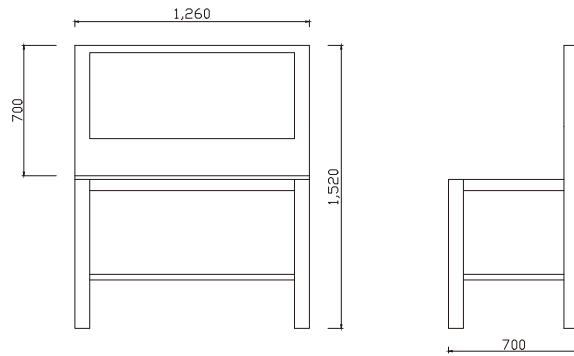

**WB50E-D**

WB50E-C With 3-Drawer Chest  
Ball Bearing Slides

	W	D	H	
<b>Overall</b>	50	27 1/2	49 1/2	in.
	1260	700	1520	mm
<b>Backpanel</b>	50	13/16	27 1/2	in.
	1260	20	700	mm
<b>3 Drawer</b>	26	12	9 7/8	in.
<b>Chest</b>	660	307	250	mm
<b>2 Drawers</b>	22 3/8	10 13/16	1 15/16	in.
	569	275	50	mm
<b>1 Drawer</b>	22 3/8	10 13/16	2 15/16	in.
	569	275	75	mm
<b>N.W.</b>	41 KGS	<b>G.W.</b>	44 KGS	<b>CUFT</b>
<b>Box 1 of 2</b>			6'	
<b>Box 2 of 2</b>	14.5 KGS	16.1 KGS	2.7'	

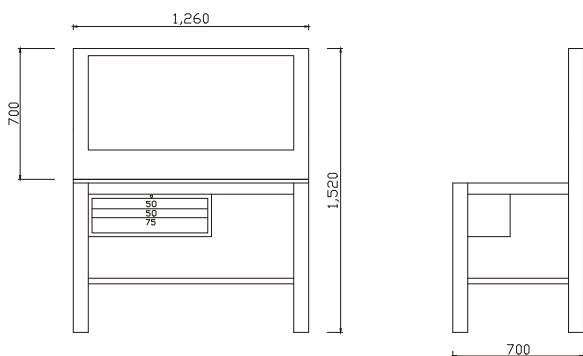





**EP212LX**

**2-Large Drawer Portable Tool Chest**  
Ball Bearing Slides

	<b>W</b>	<b>D</b>	<b>H</b>	
<b>Overall</b>	20 7/8	8 5/8	11 3/16	in.
	533	220	287	mm
<b>2 Drawer</b>	19 13/16	7 5/8	3	in.
	504	195	78.5	mm
	<b>N.W.</b>	<b>G.W.</b>	<b>CUFT</b>	
	9.6 KGS	10.3 KGS	2.05'	

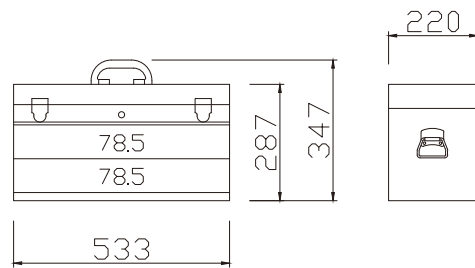

**EP213X**

**3-Drawer Portable Tool Chest**  
Ball Bearing Slides

	<b>W</b>	<b>D</b>	<b>H</b>	
<b>Overall</b>	20 7/8	8 5/8	11 3/16	in.
	533	220	287	mm
<b>3 Drawers</b>	19 13/16	7 5/8	2	in.
	504	195	51.5	mm
	<b>N.W.</b>	<b>G.W.</b>	<b>CUFT</b>	
	11.2 KGS	11.9 KGS	2.05'	

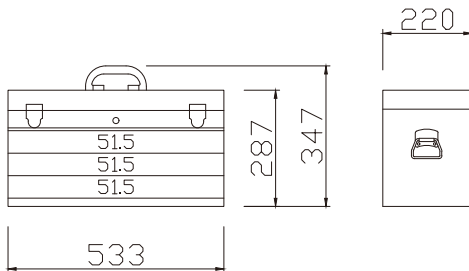



**EP214X**

**4-Drawer Portable Tool Chest**  
Ball Bearing Slides

	W	D	H	
<b>Overall</b>	20 7/8	8 5/8	11 3/16	in.
	533	220	287	mm
<b>2 Drawers</b>	9 5/16	7 5/8	2	in.
	237	195	51.5	mm
<b>2 Drawers</b>	19 13/16	7 5/8	2	in.
	504	195	51.5	mm
<b>N.W.</b>	<b>G.W.</b>	<b>CUFT</b>		
12.2 KGS	12.9 KGS	2.05'		

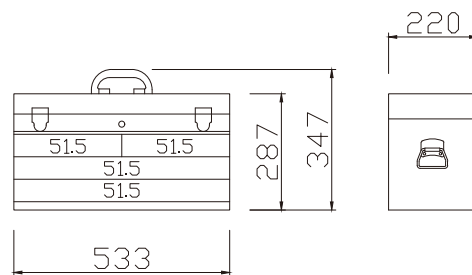

**EP223X**

**3-Drawer Portable Tool Chest**  
Ball Bearing Slides

	W	D	H	
<b>Overall</b>	21 7/8	9 7/16	11 1/16	in.
	558	247	305	mm
<b>2 Drawers</b>	19 7/8	8 7/16	2	in.
	503	215	50	mm
<b>1 Drawers</b>	19 7/8	8 7/16	3 1/16	in.
	503	215	70	mm
<b>N.W.</b>	<b>G.W.</b>	<b>CUFT</b>		
13 KGS	14 KGS	2.44'		

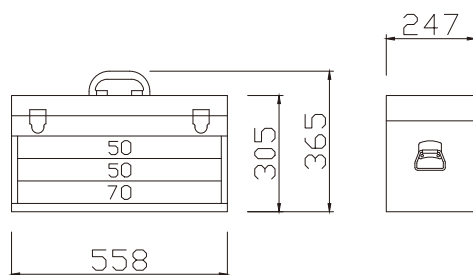

1. Heavy duty design for storage heavy duty tool.
2. Powder coating finishing.
3. 4 holes on the back of cabinet to be fixed on the wall.
4. Full opened door with 2 aluminum alloy handles.
5. Multiple numbers internal locking system for extra security.
6. Double wall door panel design, peg hole at inside wall of door.

Steel thickness:

Body: 1.0mm



## WB26

### Wall Cabinet With 20 Pcs Hooks

(AC-UH 5pcs, AC-1SH 10pcs, AC-1DH 5pcs)

	W	D	H	
Overall	26	12	23 5/8	in.
	660	305	600	mm
<b>N.W.</b>	<b>G.W.</b>	<b>CUFT</b>		
15 KGS	16 KGS	6.1'		

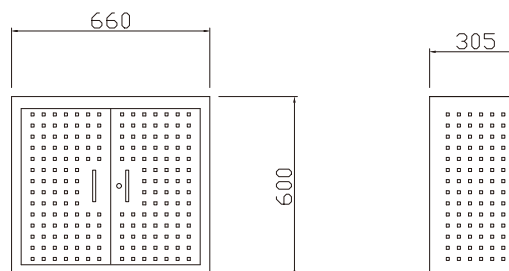

## WB32

### Wall Mount Cabinet With 20 Pcs Hooks

(AC-UH 5pcs, AC-1SH 10pcs, AC-1DH 5pcs)

	W	D	H	
Overall	32	9 13/16	35 3/8	in.
	820	250	900	mm
<b>N.W.</b>	<b>G.W.</b>	<b>CUFT</b>		
24 KGS	26 KGS	8'		

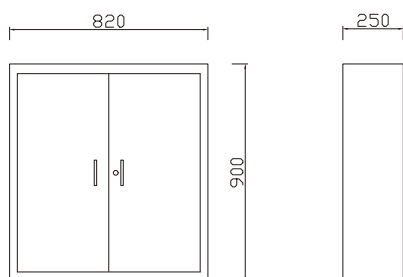

1. Heavy duty design for storage heavy duty tool.
2. Powder coating finishing.
3. 4 holes on the back of cabinet to be fixed on the wall.
4. Full opened door with 2 aluminum alloy handles.
5. Multiple numbers internal locking system for extra security.
6. Double wall door panel design, peg hole at inside wall of door.



Steel thickness:

Body: 1.0mm

**PAT. NO.**

198761(TW)  
580542(CN)  
Nr.20120728.1



## ES-2 2 Shop Cabinet With 20 Pcs Hooks

(AC-UH 5pcs, AC-1SH 10pcs, AC-1DH 5pcs)

	W	D	H	
Overall	26	17 15/16	23 5/8	in.
	660	455	600	mm
	<b>N.W.</b>	<b>G.W.</b>	<b>CUFT</b>	
	30 KGS	33.5 KGS	9.45'	

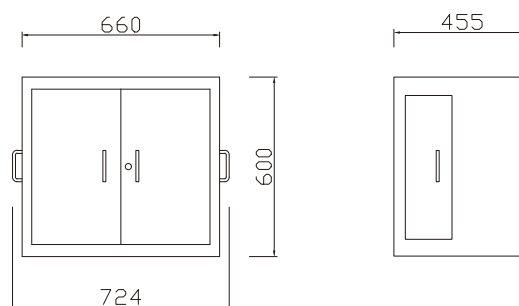

## ES-4 4 Shop Cabinet With 20 Pcs Hooks

(AC-UH 5pcs, AC-1SH 10pcs, AC-1DH 5pcs)

	W	D	H	
Overall	26	17 15/16	23 5/8	in.
	660	455	600	mm
	<b>N.W.</b>	<b>G.W.</b>	<b>CUFT</b>	
	34.9 KGS	40 KGS	9.45'	

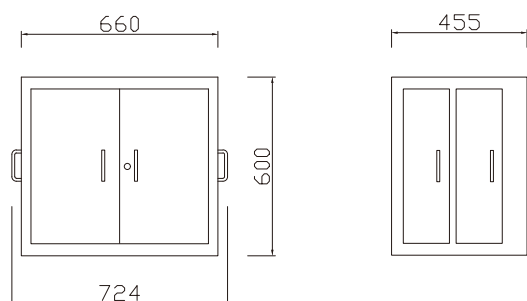



**EM0005**

5-Drawer Parts Cabinet With 5 pcs Metal Boxes  
Ball Bearing Slides

	W	D	H	
Overall	16 7/8	12	15	in.
	431	307	381	mm
5 Drawers	13 3/8	9 3/4	2 1/4	in.
	341	247	58	mm
<b>N.W.</b>	<b>G.W.</b>	<b>CUFT</b>		
24.8 KGS	27 KGS	3.3'		

**EM0005X**

5-Drawer Parts Cabinet  
Ball Bearing Slides

	W	D	H	
Overall	16 7/8	12	15	in.
	431	307	381	mm
5 Drawers	13 3/8	9 3/4	2 1/4	in.
	341	247	58	mm
<b>N.W.</b>	<b>G.W.</b>	<b>CUFT</b>		
17.9 KGS	20 KGS	3.3'		



**S23B(S)**

Parts Cabinet ( 63 mm )

	W	D	H	
Overall	23	4 5/16	17 11/16	in.
	585	110	450	mm
<b>N.W.</b>	<b>G.W.</b>	<b>CUFT</b>		
10.8 KGS	11.8 KGS	1.35'		

**S23B(L)**

Parts Cabinet ( 85 mm )

	W	D	H	
Overall	23	4 5/16	17 11/16	in.
	585	110	450	mm
<b>N.W.</b>	<b>G.W.</b>	<b>CUFT</b>		
9.8 KGS	10.8 KGS	1.35'		





**EP11-1AX**

1-Drawer Mini Top Chest  
Ball Bearing Slides



	W	D	H	
<b>Overall</b>	10 13/16	5 13/16	5 13/16	in.
	275	148	148	mm
<b>1 Drawer</b>	8 7/16	5 1/8	3 1/4	in.
	215	130	82	mm
<b>N.W.</b>	2.4 KGS	<b>G.W.</b>	2.9 KGS	<b>CUFT</b>
				0.26'

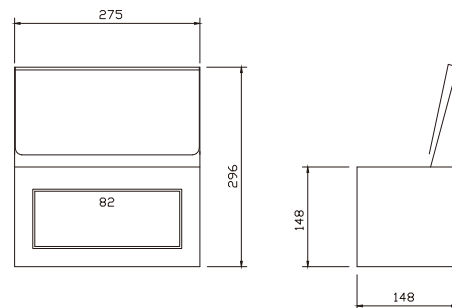

**EP11-2AX**

2-Drawer Mini Top Chest  
Ball Bearing Slides

	W	D	H	
<b>Overall</b>	10 13/16	5 13/16	5 13/16	in.
	275	148	148	mm
<b>2 Drawers</b>	8 7/16	5 1/8	1 1/2	in.
	215	130	39	mm
<b>N.W.</b>	2.8 KGS	<b>G.W.</b>	3.3 KGS	<b>CUFT</b>
				0.26'

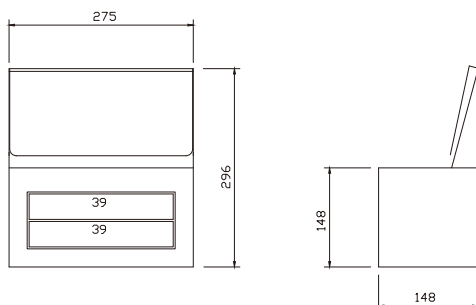



**SW11-3X**  
3-Drawer Mini Cabinet  
Ball Bearing Slides

	W	D	H	
Overall	11	5 7/8	10 3/8	in.
	284	150	264	mm
1 Drawer	8 7/16	5 1/8	1 1/2	in.
	215	130	39	mm
2 Drawers	8 7/16	5 1/8	3 1/4	in.
	215	130	82	mm
<b>N.W.</b>	<b>3.7 KGS</b>	<b>4.4 KGS</b>	<b>0.52'</b>	

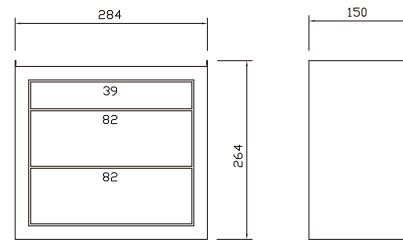

**SW11-4X**  
4-Drawer Mini Cabinet  
Ball Bearing Slides

	W	D	H	
Overall	11	5 7/8	10 3/8	in.
	284	150	264	mm
3 Drawers	8 7/16	5 1/8	1 1/2	in.
	215	130	39	mm
1 Drawer	8 7/16	5 1/8	3 1/4	in.
	215	130	82	mm
<b>N.W.</b>	<b>4.2 KGS</b>	<b>4.9 KGS</b>	<b>0.52'</b>	

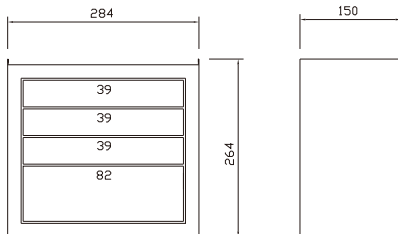

**SW11-5X**  
5-Drawer Mini Cabinet  
Ball Bearing Slides

	W	D	H	
Overall	11	5 7/8	10 3/8	in.
	284	50	264	mm
5 Drawers	8 7/16	5 1/8	1 1/2	in.
	215	130	39	mm
<b>N.W.</b>	<b>4.6 KGS</b>	<b>5.3 KGS</b>	<b>0.52'</b>	

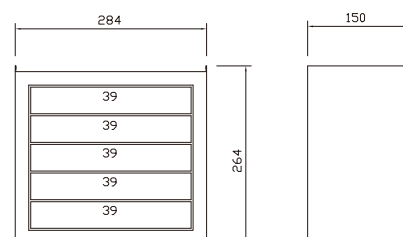



**EA-01**  
Metal Box  
Size: 333mm(W) x 235mm(D) x 50mm(H)

**PAT. NO.**

218171(TW)  
600435(CN)  
US 6837467 B2  
Nr.20308137.4



**EA-02 [15"]**  
Side panel for W26 series  
Without paper Without vise



**EA-03**  
Bottle side tray for W26 series



**EA-04**  
Workpanel for W26 series  
Size: 656mm x 500mm x 30mm

**PAT. NO.**

218171(TW)  
600435(CN)  
US 6837467 B2  
Nr.20308137.4



**EA-05 [18"]**  
Side panel for W26 series,  
ET series, W15 series  
Without paper



**EA-06**  
Carry tray for EP222 series &  
EP333 series



**EA-07**  
Top tray for  
W26 series

**PAT. NO.**

M274214(TW)  
822622(CN)  
Nr.202005007577.9



**EA-08**  
T-BAR for W26 series  
Without paper

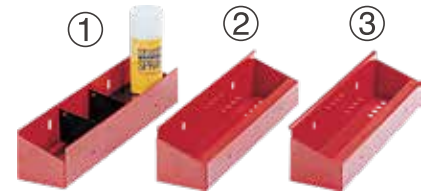

**EA-09**  
Side tray for W26 series

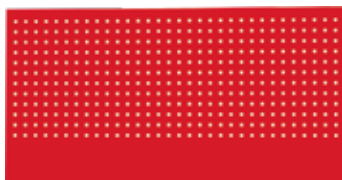

**EA-10**  
Display panel  
Size: 1525mm x 700mm x 20mm



**EA-11**  
Paper holder for W26 series  
Without paper



**EA-12**  
Bumper for W26 series  
Material: EPDM

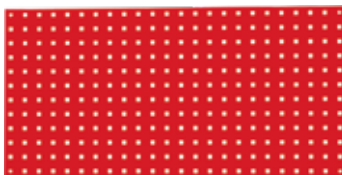

**EA-13**  
Display panel  
Size: 443mm x 887mm x 15mm

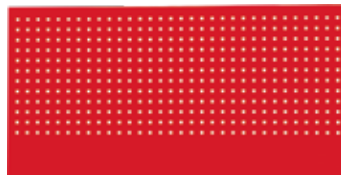

**EA-14**  
Display panel  
Size: 1260mm x 700mm x 20mm



**EA-17**  
Wrench holder for W26 series  
Without tools



**EA-18**  
T-BAR for W26 series  
Without tools



**AC-MAT01**  
10mm thickness top liner for W26 series  
Size: 660mm x 450mm x 10mm  
Material: EVA



**EA-15**  
Side panel for W26 series  
Without tools  
Size: 673mm x 455mm x 30mm



**PAT. NO.**  
M294251(TW)  
Material: EPDM

**EA-16**  
Bumper for W26 series  
Material: EPDM

滾滾長江東逝水



**AC-PIN**  
Pin could be inserted on any hole of mat to set up hand tools



**AC-MAG**  
Magnetic tool holder  
Size: 458mm x 52mm x 17mm

**AC-MAT02**  
10mm thickness drawer liner for W26 series  
Size: 575mm x 377mm x 10mm



**AC-UH**  
U Shape Hook



**AC-1SH**  
1" Single Hook



**AC-1DH**  
1" Double Hook



**AC-2SH**  
2" Single Hook



**AC-2DH**  
2" Double Hook



**AC-4SH**  
4" Single Hook



**AC-4DH**  
4" Double Hook



**AC-8SH**  
8" Single Hook



**AC-8DH**  
8" Double Hook



**AC-TOH01**  
Tool Holder 500mm(L)



**AC-MAG59**  
Magnetic tool holder for workbench backpanel  
Size: 458mmx52mmx17mm

**AC-T01**  
Drawer tray  
Material: PS  
Size: 569mm x 104mm x 40mm



**AC-T02**  
Drawer tray  
Material: PS  
Size: 189mm x 270mm x 40mm



**AC-T03**  
Drawer tray  
Material: PS  
Size: 189mm x 270mm x 40mm



**AC-T04**  
Drawer tray  
Material: PS  
Size: 189mm x 270mm x 40mm



**C-T06**  
Drawer tray  
Material: PS  
Size: 189mm x 270mm x 40mm



**AC-T09**  
Drawer tray For EA-01  
Material: PS  
Size: 236mm x 335mm x 43mm



**AC-T12**  
Drawer tray For EA-01  
Material: PS  
Size: 236mm x 335mm x 43mm





**EB-01**



**EB-01 + C01**

Drawer tray with cover  
Material: HIPS  
Size: 87mm x 87mm x 42mm



**EB-03**



**EB-03 + C03**

Drawer tray with cover  
Material: HIPS  
Size: 278mm x 87mm x 42mm

**AC-DIV1**

Steel drawer divider for cabinet  
(Base + 2 long dividers + 2 short dividers)

**AC-DIV11**

Base

**AC-DIV12**

Long divider  
Size: 560mm x 40mm

**AC-DIV13**

Short divider  
Size: 368mm x 40mm

**PAT. NO.**

M249555(TW)  
621865(CN)  
US 6837467 B2  
Nr.20308137.4

M249558(TW)  
621905(CN)  
Nr.20312086.8



**AC-DIV2**

Steel drawer divider for top chest & middle chest  
(Base + 2 long dividers + 2 short dividers)

**AC-DIV21**

Base

**AC-DIV22**

Long divider  
Size: 555mm x 40mm

**AC-DIV23**

Short divider  
Size: 265mm x 40mm



**AC-DIV31**

Plastic drawer divider for tool chest  
(2 short dividers + 2 long dividers)

**AC-DIV32**

Plastic drawer divider for cabinet  
(2 short dividers + 2 long dividers)

**AC-DIV33**

Plastic divider for top area of tool chest  
(2 short dividers + 2 long dividers)

